

Since 1964, the leader in effective, safe and reliable products for fisheries conservation.
Knowledgeable biologists depend upon Smith-Root equipment.

USER'S MANUAL

LR-24 Electrofisher



SMITH-ROOT, INC.
Technology For Fisheries Conservation

smith-root.com

#07288.04

Contents

Introduction

The LR-24 Electrofisher.....	1
------------------------------	---

Overview

General Information	2 - 4
---------------------------	-------

Status Display

Input	5
Output	5
Waveform	6

Display Panel Menu Key Descriptions

Display Panel	7
Volts	7
Frequency.....	7
Duty Cycle.....	7
Down Arrow.....	8
Enter.....	8
Up Arrow	8
Recall Set up.....	8
Store Set up.....	8
System Menus 0-8.....	9
Power Limit	14
Pulse Types.....	14

Battery Compartment & Connector Descriptions

Battery Compartment.....	18
Battery Connector	18
Anode and Cathode Connectors.....	18
Control Connector.....	18

Safety Feature Descriptions

Emergency Shutdown Switch.....	19
Quick Release Pack Frame.....	19
Flashing Red Light	19
Audio Alarm	20
Anode Switch	20
Tilt Switch.....	21
Immersion Sensor	21
Anode Out of Water	21
Output Voltage Detector.....	21
Electronic Circuit Breaker	21

Battery Compartment Interlock Switches	22
Fusible Links	22
Temperature Sensors and Overheating	22
Peak Current Overload	23
Output IGBT Failure	23
Average Current Overload.....	23
Low Battery Fault	24

Set up and Operation

Set up.....	25
Using Recalled Waveforms for Set up	28
Factory Default Stored Waveforms	29
Custom Set up Procedure	30
Burst of Pulses Waveforms	32
Dual Output Mode.....	34
Storing Waveform Settings.....	36
Specifications.....	37
My Custom Waveforms.....	38

Battery Care and Maintenance

Charger	39
Maintenance Charger & Diagnostic Equipment.....	44

Electrofishing Safety

Safety	45
--------------	----

Appendix A

Glossary of Terms	50
-------------------------	----

Appendix B

LR-24 Event Codes	51
-------------------------	----

Appendix C

Electrofisher Operation Hints	52
-------------------------------------	----

Appendix D

Factory Default Stored Waveforms	53
--	----

Appendix E

Pack Adjustments	54
------------------------	----

Appendix F

Cleaning and Maintenance	56
--------------------------------	----

Appendix G

Model 12-B Conversion Chart	56
-----------------------------------	----

Appendix H

Electrode Pole Testing	57
------------------------------	----

Appendix I

Cathode Testing	57
-----------------------	----

Appendix J

Anode/Electrode Pole Tester	57
-----------------------------------	----



The LR-24 is the most advanced Electrofisher ever produced. Its design incorporates many new safety features to help protect both operating personnel and fish. Many features are refinements of conventions established in earlier SRI electrofishers and some are entirely new.

The user interface has been designed to make the LR-24 easy to use. With the Quick Set up feature, the LR-24 automatically sets output voltage,

The LR-24 has many features that will increase the collection capabilities - with greatly enhanced safety to both operators and wildlife.

frequency and duty cycle. An immersion sensor automatically turns the output off if the bottom of the pack frame comes into contact with the water. The anode-out-of-water detector automatically turns off the output if the anode ring is raised out of the water while the output is on.

Taking the time to familiarize yourself with these features will go a long way towards learning how to use the LR-24 in the most efficient manner.



Items manufactured by companies other than Smith-Root carry the original manufacturer's warranty. Please contact product manufacturer for return instructions.

All Smith-Root, Inc. manufactured products are covered by a one-year warranty.

Credit & Refund Policy: Customers returning equipment - in new condition - will be given a refund within five days from the date of the return. A return authorization must accompany returns. Valid equipment returns include, but are not limited to, ordering incorrect equipment, funding deficits and defective equipment returned for reimbursement. All returns are subject to a restocking fee and applicable shipping charges. The restocking fee is figured at 10% of the purchase price but not less than \$20.00. Customers receiving equipment in damaged condition will be referred to the shipping company for insurance reimbursement.

LR-24

BACKPACK ELECTROFISHER

Overview

LR-24 Controls and Features

Take the time to familiarize yourself with the LR-24's features before beginning electrofishing.

1 - Emergency Shutdown Switch

The main on/off switch for the LR-24. The switch must be rotated 90 degrees clockwise to prevent accidentally powering up the unit. Simply pushing down will turn it off.

2 - Keypad

Allows the display and modification of many control parameters of the LR-24.

3 - Menu Display

Displays settings and status of LR-24.

4 - Flashing Red Light

Flashes to indicate that the output is on.

5 - Battery Compartment Cover

Covers battery and connectors. Must be properly in place and latched for unit to function.

6 & 7 - Audio Alarms (Left, right)

Sounds to indicate that the unit is on.

8 - Packframe

Main connecting point for the harness system. All components are mounted on the packframe.

9 - Battery Compartment Latch

Three twist-lock latches secure the battery cover to the main control box and packframe.

10- Cathode Cable

a molded strain relief allows the cathode cable to pass through slots in the battery cover, either in side (as shown), or bottom.

11- Anode Cable

A molded strain relief allows the anode cable to pass through slots in the battery cover, either in side (as shown), or bottom.



LR-24 shown without harness system

12- Immersion Sensor

This sensor will shut the unit down, should the LR-24 be immersed in water.

13- Serial Number

Unique number to identify the unit for service.

Display Panel Key Overview

The panel has 11 keys that perform a variety of functions. The display is a 4 line 20 character per line vacuum fluorescent display. The bright blue/green characters can be clearly seen in most lighting situations but may require shading in direct sunlight.

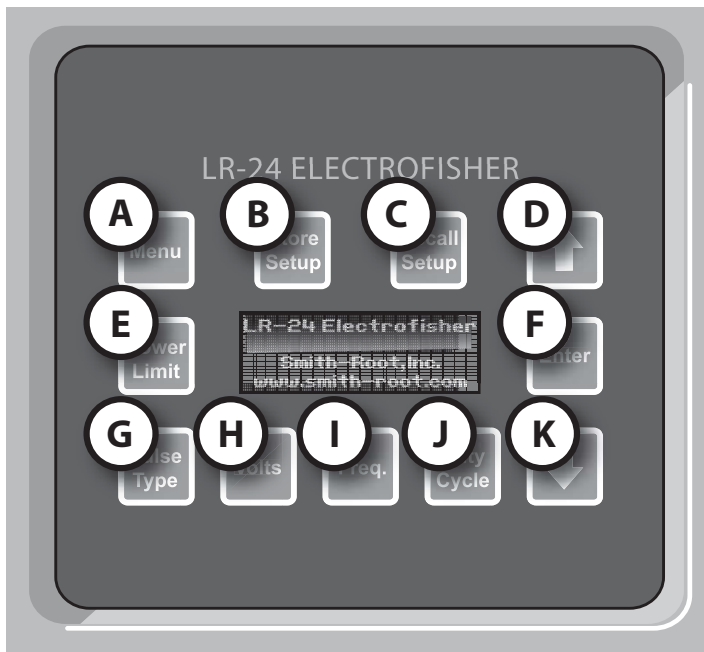

Fig. 1.2 - LR-24 Key pad with fluorescent display

A - Menu Key

Displays the system menu options. Press arrow up or down to scroll through options. Press menu again to escape.

B - Store Set up Key

Allows the user to store the settings of the electrofisher in one of ten storage locations.

C - Recall Set up Key

Recalls one of ten factory default or user stored electrofisher settings.

D - Up Arrow Key:

- Increases the selected setting
- Scrolls up through a menu
- Changes to the next status display

E - Power Limit Key

Displays and allows the modification of the power limit setting.

F - Enter Key

Selects menu items or enters settings into the selected function and then returns to the main status display.

G - Pulse Type Key

Displays and allows the modification of the pulse type setting.

H - Volts Key

Displays and allows the modification of the voltage setting.

I - Freq. Key

Displays and allows the modification of the output frequency setting.

J - Duty Cycle Key

Displays the output duty cycle setting and pulse width in milliseconds.

K - Down Key:

- Decreases the selected setting
- Scrolls down through a menu
- Changes to the previous status display

See **DISPLAY PANEL MENU KEY DESCRIPTIONS** for more information on each key.

LR-24

BACKPACK ELECTROFISHER

Overview

The LR-24 has many features that will increase the collection capabilities with greatly enhanced safety to both operators and wildlife.

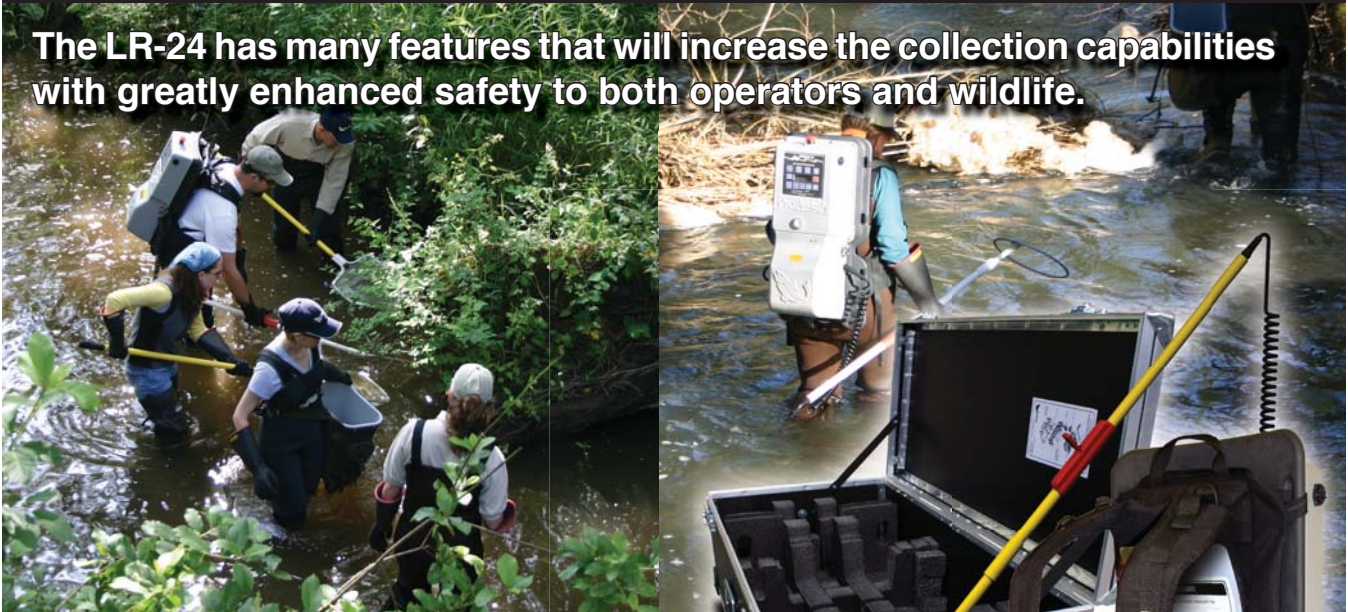

The LR-24 has better output regulation and allows greater user control of the output than any electrofisher before. We suggest that you try quick set up first. You may find that you use less voltage and a lower frequency than with other electrofishers. This should lower fish injury rates and has the added benefit of longer shocking time per battery charge.

In all cases, electrofishers should be set up by observing fish behavior and recovery times, not by voltage or current measurements.

The LR-24 remembers the settings that were last used and powers up with these settings. There are 10 storage locations for different voltage, frequency and duty cycle set ups for use at any time. The set ups stored in these locations can be recalled quickly for use at different sites.

A new pack suspension system allows for maximum flexibility and comfort.

New and finer control over the output helps reduce injuries to fish.

Power limit mode allows the user to set a maximum output power level that the LR-24 will not exceed.

Dual output mode lets the user set up 2 different waveforms and voltages and switch from the first to the second in less than a second by simply double “clicking” (pressing) the anode pole switch. The user can then switch back to the first waveform and voltage by releasing the anode pole switch for more than one second, then pressing it again.

Status Display

When first turn on the LR-24, a screen will briefly appear displaying the model number, Software version and Smith-Root, Inc.s' web address. The status display screen will automatically appear after a few seconds.

The LR-24 has **3 standard screens** referred to as "status screens" that are displayed during operation.

Specifically, they are:

- The input status screen.**
- The output status screen.**
- The waveform screen.**

1.) Input Status Screen

A sample input status screen is shown in Fig 1.1.

The first line shows the shocking time in seconds. The LR-24 keeps track of fractions of a second but only displays 1 second resolution. The second line shows battery condition in a fuel gauge fashion. 24.0V or more and the fuel gauge shows full. At approximately 20.5V the gauge shows empty. At 20.0V the LR-24 shuts off the output because of a low battery. The third line is the battery meter. It shows the battery voltage and the battery current in amps. The LR-24 overloads and shuts off its output if the battery current reaches 20.0A or more. The fourth line displays the air temperature in the box and the temperature of the heat sink.

See Safety Features, under Temperature Sensors for a description of operating temperatures parameters. Refer to System Menu 4 for an explanation of Thermal Power Foldback feature.

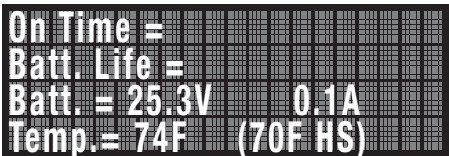

Fig. 1.1

2.) Output Status Screen

A sample output status screen is shown in Fig. 1.2.

The first line shows the shocking time in seconds. The second line shows the average and in parentheses peak power, that the LR-24 is putting into the water. This peak reading is calculated by multiplying together the peak output voltage and peak output current. The average power is calculated by multiplying the peak power by the duty cycle. The third line shows the average output voltage and in parentheses the peak output voltage. The fourth line shows the average output current in amps and in parentheses the peak output current in amps.

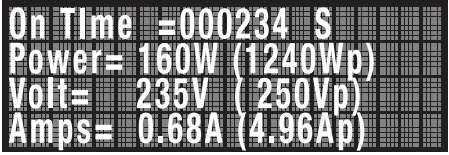

Fig. 1.2

Status Display (Cont.)

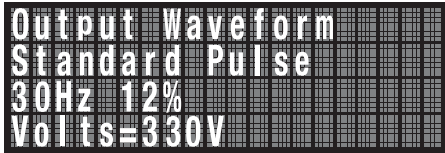

Fig. 1.3

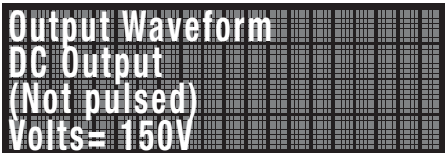

Fig. 1.4

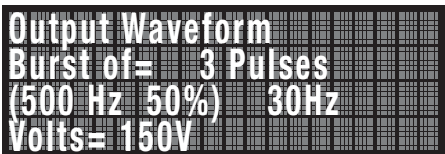

Fig. 1.5

3.) Waveform Screen

A sample waveform screen is shown in Fig. 1.3.

The first line will have "output waveform", unless dual output is turned on (see System Menu 2 - Dual Output). In this case, the first line will indicate primary waveform or secondary waveform. The second line describes the type of pulse. There are three types of pulses, **Standard Pulse**, **DC** and **Burst of Pulses**.

If Standard Pulse has been selected as the output waveform, the screen will appear as in Figure 1.3. The third line shows the frequency and duty cycle of the standard pulse. The fourth line shows the presently selected output voltage.

If DC has been selected as the output waveform, the screen will appear as in Figure 1.4. The third line will indicate there is no pulse and the fourth line shows the presently selected output voltage.

If Burst of Pulses has been selected as the output waveform, the screen will appear as in Figure 1.5. The second line will indicate the number of pulses selected in the burst. The third line will indicate in parentheses the frequency and duty cycle of the burst of pulses and the number on the right indicates the frequency of which the burst of pulses occur. The fourth line shows the currently selected output voltage.

Volts Key

When the Volts key is pressed, the display shows the output voltage setting and asks for a new setting. Pressing the arrow keys allows the user to change the output voltage. Pressing the Enter key enters the settings and returns to the status screen. The range of this control is from 50 volts to 990 volts in 5 volt steps. Pressing the Volt key a second time will abort this function and return to the status screen. Pressing another function key (other than the arrow keys) will abort this function and move to the set up display for the key that was pressed.



Volts Key

Display Panel Key Descriptions

Freq. Key

When the Freq. key is pressed the display shows the output frequency setting and asks for a new setting. Pressing the arrow keys allows the user to change the output frequency. Pressing the Enter key enters the settings and returns to the status screen. The range of this control is from 1Hz to 120Hz in 1Hz increments. Pressing 'Freq.' a second time will abort this function and return to the status screen. Pressing another function key (other than the arrow keys) will abort this function and move to the set up display for the key that was pressed.



Freq. Key

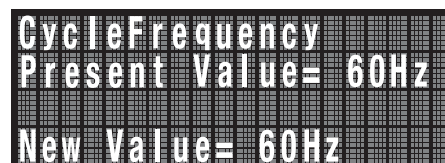

Fig. 2.1

Duty Cycle Key

When the Duty Cycle key is pressed the display shows the output duty cycle setting and pulse width in milliseconds and asks for a new setting. Pressing the arrow keys allows the user to change the output duty cycle. Pressing the Enter key enters the settings and returns to the Status Screen. The range of this control is from 1% or 0.1 milliseconds, whichever is larger, to 99% in 1% increments. Pressing the Duty Cycle key a second time will abort this function and return to the Status Screen. Pressing another function key (other than the arrow keys) will abort this function and move to the set up display for the function key that was pressed. Duty cycle is the percentage of time the output pulse is on compared to the time from the start of one output pulse to the start of the next output pulse. For example, if the selected waveform is 60 Hz with 25% duty cycle, an output pulse will occur 60 times per second or once each 16.7 mSec. the pulse width will be $.25 \times 16.7 \text{ mSec.} = 4.2 \text{ mSec.}$



Duty Cycle Key

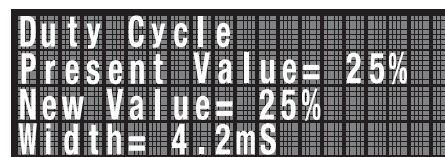
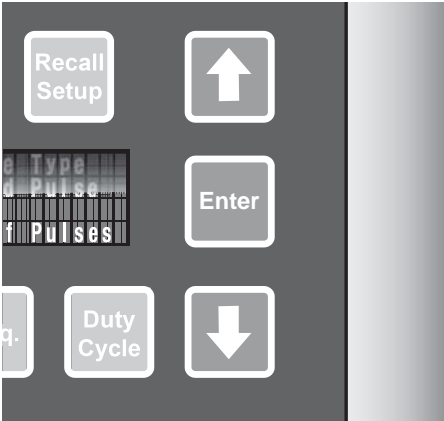

Fig. 2.2

Display Panel Menu Key Descriptions (Cont.)



Up, Enter and Down Keys

Down Arrow Key

Decreases the selected setting or scrolls down through a menu or scrolls to the next status display.

Enter Key

Selects menu items or enters settings into the selected function and then returns to the main status display. Changes to the settings take place only after the Enter Key is pressed.

Up Arrow Key

Increases the selected setting or scrolls up through a menu or changes to the next status display.

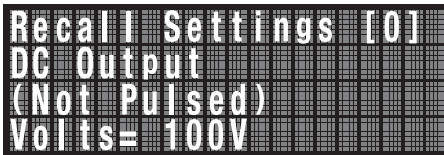

Fig. 2.3

Recall Set up Key

Recalls one of ten factory default or user stored electrofisher set ups. Use the arrow keys to scroll through the set ups and the Enter key to select the displayed set up. These set ups can be used for different work areas or streams. Pressing the Recall Set up key a second time will abort this function and return to the main status display. Pressing another function key will abort this function and move to the set up display for the function key that was pressed.

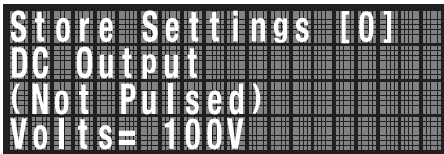
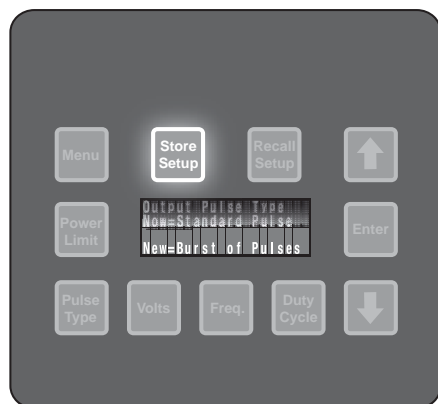

Fig. 2.4

Store Set up Key

The Store Set up key allows the user to store the settings of the electrofisher in one of ten storage locations. When a setting is displayed that wish to store, press the Store Set up Key. When the Store Set up key is pressed, the contents of the first storage location are displayed. Scroll through the storage locations using the arrow keys. This will show what is already stored in that location. When the Enter key is pressed, the set up in the currently displayed storage area is overwritten and the new voltage, frequency, duty cycle and waveform settings are stored in this area. This can decrease sample variations due to set up differences. These settings can be stored for up to 10 years without power connected to the electrofisher. Pressing the Store Set up key a second time will abort this function and return to the Status Screen. Pressing another key (other than the arrow keys) will abort this function and move to the set up display for the function key that was pressed. The factory default settings for the 10 storage locations can be restored at any time using the Menu key and selecting option 7



Store Set up Key

Display Panel Menu Key Descriptions (Cont.)

SYSTEM MENU KEY (0-8)

Allows the user to access additional functions of the LR-24. Additional functions include reset the timer, use the quick set up, access dual output mode, restore factory defaults for waveforms, set the power limit mode, run extended system diagnostics and examine the event history. Only one item is displayed at a time. can scroll through the menu using the arrow keys. Pressing the Enter key will execute the command and return to the main status display or display a sub-menu if necessary for that item. Pressing the Menu key a second time will abort this function and return to the main status display. Pressing another function key will abort this function and move to the set up display for the function key that was pressed.

System Menu 0: Time Reset

The reset timer option allows the user to reset the on-time seconds counter back to zero. Press enter to reset the timer. Press any other key to exit without resetting the timer (see Figure 2.5).

System Menu 1: Quick Set up

If the Quick Set up option is selected, the LR-24 automatically sets the waveform, duty cycle and output voltage to suit the present water conductivity. It will use a default waveform of 30Hz 12% duty cycle and will adjust the output voltage as necessary to reach 25 watts average power output. While the LR-24 sets its output up for 25 watts average output power, the power limit is still set at 400 watts average power. The user may change any of the settings determined by the LR-24 after the set up cycle is complete. The anode and cathode should be in the water in a normal operating position when the Quick Set up cycle is started (see Figures 2.6 and 2.7).

After running Quick Set up, a confirmation message similar to this appears on the screen.

When this message appears, the LR-24 is ready to begin electrofishing. may see what settings quick set up chose by using the arrow keys on the front panel.

Note: As the electrodes move thru the water, the power applied to the water changes. It may increase well above the initial 25 watt level or it may decrease well below that level. The output voltage determined by the Quick Set up routine will be maintained until it is changed by the user or the power limit is reached or an overload occurs.

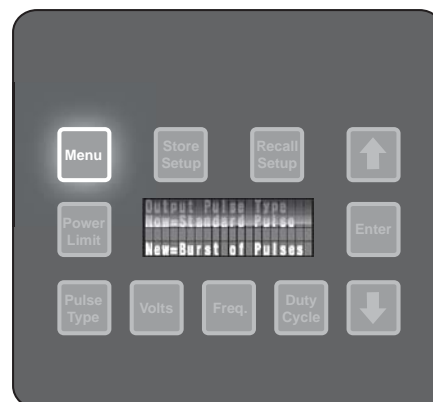

Menu Key

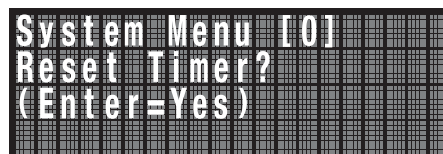

Fig. 2.5

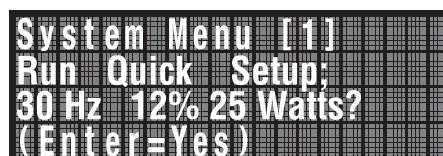

Fig. 2.6

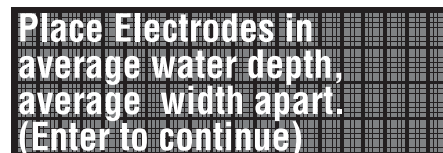

Fig. 2.7

Display Panel Menu Key Descriptions (Cont.)

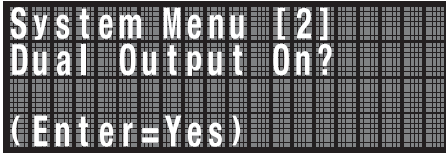

Fig. 2.8

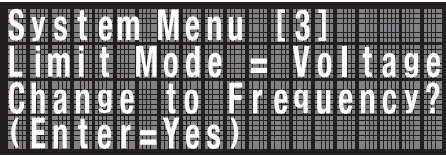

Fig. 2.9



Fig. 2.10

System Menu 2 : Dual Output

Dual output on/off allows the user to turn dual output mode on or off. Dual output mode allows the user to set up and switch between two completely independent sets of waveforms and voltages by simply releasing and pressing the anode pole switch in less than 1 second. The primary waveform and voltage, the one entered first, is the one activated when press the anode pole switch the first time. The secondary waveform and voltage is activated by releasing and pressing the anode pole switch in less than 1 second. This feature allows the user to change voltages and waveforms quickly. This can help reduce injuries to adults when collecting young of the year. When using a low frequency waveform to get catfish to move off the bottom and then quickly changing to a higher frequency waveform to collect them. Any combination of pulse types, voltages, frequencies, duty cycles and power limits may be used for the two outputs in dual output mode. To see or make changes to either the primary or secondary waveform, from the main status waveform screen, press the Up arrow key until the display shows the primary waveform. Make changes using the volts, freq. and duty cycle keys. Pressing the Up arrow key one more time will display the secondary waveform and may make changes to it in the same way the primary waveform was changed. To change back to the primary waveform, release the pole switch for more than 1 second and then press it again.

System Menu 3: Power Limit Mode

This menu item allows the user to select the method for controlling the maximum average output power of the LR-24. If the user-set power limit is reached, the LR-24 will automatically decrease the output voltage or frequency, as selected by the user, to maintain the output power at that limit. If the output power drops below the limit then the LR-24 will automatically increase the voltage or frequency back to the user set value.

System Menu 4: Thermal Power Fold Back Mode

This menu option allows the user to turn Thermal Power Limiting on or off. On hot days, when the LR-24 is putting out 200 watts or more, it may eventually overheat and shut down to prevent possible damage to the electronics. Thermal Power Limiting allows the LR-24 to better control the amount of internal heat being produced and in many cases can prevent thermal shutdown. This feature allows the LR-24 to continue to function in hot environments where it would otherwise shutdown. When this option is turned on the LR-24 will automatically reduce its output frequency if one of the pulsed outputs

Display Panel Menu Key Descriptions (Cont.)

has been selected or it will reduce its output voltage if DC output has been selected. The LR-24 reduces the output by 20% for every 2 degree Fahrenheit above the trip point, up to a maximum of 80% reduction.

The LR-24 has two thermal sensors inside: one monitors the air temperature inside the electronics cover and the other monitors the temperature of the heat sink. The trip points are 150 degrees for the air temperature and 190 degrees for the heat sink temperature. The shutdown temperature for the air is 160 degrees and 200 degrees for the heat sink. If either of the shut down temperatures is reached, the LR-24 will shut down even if Thermal Power Limiting is enabled. With Thermal Power Fold Back enabled when either of the trip points is reached, the LR-24 will begin to beep both audio alarms simultaneously and the status screen will look similar to that shown in **Figure 2.11**.

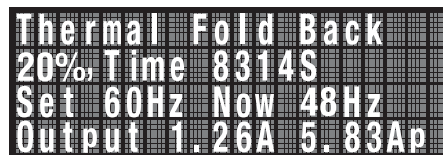

Thermal Fold Back
20% Time 8314S
Set 60Hz Now 48Hz
Output 1.26A 5.83Ap

Fig. 2.11

This display says that the LR-24 has entered thermal power limiting. The output frequency has been reduced by 20%. The output frequency was set to 60Hz and has been reduced to 48 Hz. The average output current is 1.26 amps and the peak output current is 5.83 amps. If the temperature continues to rise, the LR-24 will continue to reduce the output in 20% steps to a maximum of 80%. This status display can be seen as long as the pole switch is pressed. When the pole switch is released, the standard status screen will return. This allows continued monitoring of battery condition, or the temperature of the LR-24. As the LR-24 cools down the output is automatically increased back toward the original settings. The LR-24 will not increase the output beyond the original settings.

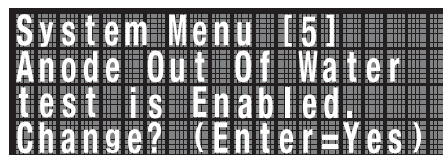

System Menu [5]
Anode Out Of Water
test is Enabled.
Change? (Enter=Yes)

Fig. 2.12

System Menu 5: Anode Out Of Water Disable

Allows the temporary override of the Anode Out of Water feature. This option allows the LR-24 to be used in very shallow water, where it may not be possible to keep the anode in the water all of the time. This option is only active while the LR-24 is powered on and the mode resets to “Enabled” on power up.

Display Panel Menu Key Descriptions (Cont.)

```
System Menu [6]
Run Extended System
Test?
(Enter=Yes)
```

Fig. 2.13

```
WARNING: Dangerous
Voltages will be
output during test!
Continue? (↑=Yes)
```

Fig. 2.14

```
Testing Memory...
```

Fig. 2.15

```
Testing Memory...
Check= BC86
Testing Inverter
```

Fig. 2.16

```
*1st Test Passed*
Connect Electrodes
to Test Load, Close
Pole Switch...
```

Fig. 2.17

```
***Tests Passed***
Batt: 24.8V E■■■■■F
In: 109.9W Out: 79.8W
Efficiency: 72.6%
```

Fig. 2.18

System Menu 6: Extended System Test

This is a diagnostic test mode for test and service technicians. It requires the use of a standardized test load connected to the anode and cathode.

During the test the LR-24 checks its program memory for errors, then it checks the operation of the output safety relay, the output switch (IGBT), the accuracy of the five internal voltage ranges, estimates the charge in the battery and measures the efficiency of the high voltage converter. This test takes approximately 20 seconds to run. To run the test, follow the instructions on the screen. See **Figure 2.13**.

The user must press the Up arrow key to continue the test pressing any other key will abort the test and return to the status display (**Figs. 2.14-2.15**).

Followed in a few seconds by the screen in **Fig. 2.18**.

If the relays and regulation pass the test, the following message will appear on the display, indicating the first series of testing passed (**Fig. 2.17**).

The next part of the test requires that the output of the LR-24 be connected to a test load or that the electrodes be in water. This part of the test takes about 15 seconds to complete. When it is finished, the output of the LR-24 will automatically turn off.

If the LR-24 passes this part of the test this message will be displayed. (**Fig. 2.18**)

This information is displayed for as long as the pole switch is held down.

The use of a non-standard test load or electrodes in water will probably yield different efficiency numbers.

Display Panel Menu Key Descriptions (Cont.)

System Menu 7: Restoring Factory Default Settings

Restore factory defaults restores the original factory set voltages and waveforms in the 10 waveform storage locations. All the current settings will be changed back to the Factory Default Settings. See Appendix D for a list of Factory Default Settings.

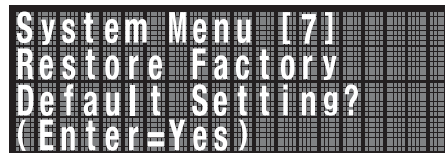

Fig. 2.19

This message will be displayed before the default settings are restored and the user must press the Up arrow key to confirm restoration of those settings (See Fig. 2.20). Pressing any other key will abort this operation and return to the status display.



Fig. 2.20

System Menu 8: Event History

The LR-24 records all errors and unusual events that occur during use. This menu option allows a technician to review the status codes stored during field use of the LR-24 (See Fig. 2.21).

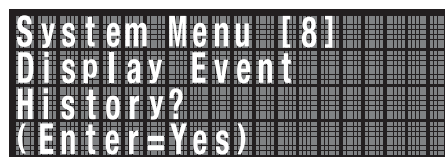

Fig. 2.21

This history file is an aid to troubleshooting if the LR-24 develops a problem. There is a table of error codes in Appendix B of this manual. To exit from this mode and return to the status screen. Press the enter key (See Fig. 2.22).

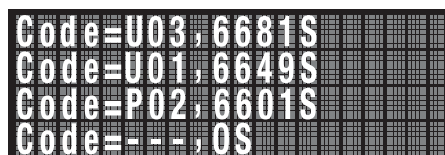

Fig. 2.22

Display Panel Menu Key Descriptions (Cont.)



Fig. 2.23



Power Limit Key

Power Limit Key

The Power Limit Key allows the user to pre-set an output limit where desired out of safety considerations.

When the Power Limit key is pressed, the setting is displayed and can be changed by using the arrow and Enter keys.

Pressing the Power Limit key again will abort this function and return to the main status display. Pressing another key will abort this function and move to the set up display of the key that was pressed. The power is limited by lowering the output voltage or frequency, which the user selects from the Limit Mode option under the Menu key. The minimum output voltage is 50 volts. If this lower voltage limit is reached and the power limit is still being exceeded, the LR-24 will shutdown its output and an error message will be displayed. This control does not affect the output unless the user set power limit is reached. The power limit cannot be set higher than 400 watts average output power.

In Burst of Pulses mode, if the power limit is reached and if the limit mode is set to frequency, only the cycle frequency will be reduced. The frequency of the pulses in the burst is not changed. For an explanation of cycle and burst frequencies, see Pulse Type, below.

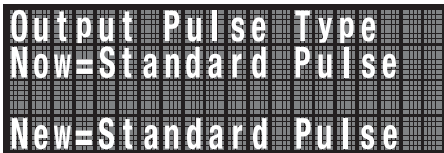

Fig. 2.24



Pulse Type Key

Pulse Type Key

Allows the user to Enter the output waveform of the LR-24. Available waveforms are DC, Standard Pulse and Burst of Pulses.

The output pulse type can be changed by using the Up or Down arrow keys. When DC is selected, the output of the LR-24 is smooth DC at the selected voltage and power limit settings.

Standard Pulse is a waveform that produces continuous output pulses of the selected voltage, duty cycle, frequency and power limit. For example, 60Hz 25% duty cycle 300 volts and 100 watts average power limit, would produce a 300 Volt pulse 4.2 milliseconds wide, (25% duty cycle), 60 times per second unless the power limit of 100 watts average power is reached. If the power limit is reached then the LR-24 will automatically reduce the output voltage or frequency, whichever one the user has selected, to maintain 100 watts average output power.

Display Panel Menu Key Descriptions (Cont.)

Burst of Pulses

Burst of Pulses is a complex waveform wherein a lower frequency waveform is used to turn on and off a higher frequency waveform. The lower frequency is called the cycle frequency. The higher frequency is called the burst frequency. For example, a burst of 3 pulses at 400 Hz with a 12% duty cycle and a 40 Hz cycle frequency would produce the following output:

A pulse would occur every 2.5 milliseconds, (400 Hz) and each pulse would be 0.3 milliseconds wide, (12% of the 400 Hz). After the first 3 pulses of the 400 Hz waveform the next 7 pulses of this waveform would be skipped. Then there would be another 3 pulses of the 400 Hz 12% duty cycle waveform. For this waveform the bursts of pulses occur every 25 milliseconds, (40 Hz). This pattern would repeat as long as the switch on the anode pole was held down. For this example, the LR-24 could not output more than 10 pulses of the 400 Hz burst because 400 Hz is only 10 times the cycle frequency of 40 Hz.

As a second example, if the LR-24 were set to produce a burst of 5 pulses at 250 Hz and 10% duty cycle at a 15 Hz cycle frequency, the waveform would have these characteristics:

A pulse would occur every 4 milliseconds, (250 Hz), each pulse would be 0.4 milliseconds wide, (10% of the 250 Hz). After 5 pulses of the 250 Hz waveform, the next 11 pulses of this waveform would be skipped. Then there would be another 5 pulses of the 250 Hz 10% duty cycle waveform. For this waveform, the bursts of pulses occur every 67 milliseconds (15 Hz). This pattern would repeat as long as the switch on the anode pole was held down. For this example, the LR-24 could not put out more than 16 pulses of the 250 Hz burst because 250 Hz is only 16.67 times the cycle frequency of 15 Hz.

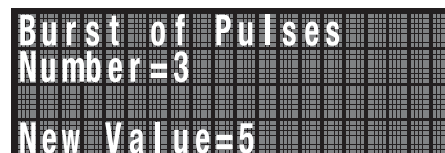

Burst of Pulses
Number=3
New Value=5

Fig. 2.25

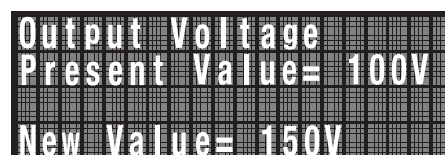

Output Voltage
Present Value= 100V
New Value= 150V

Fig. 2.26

Display Panel Menu Key Descriptions (Cont.)

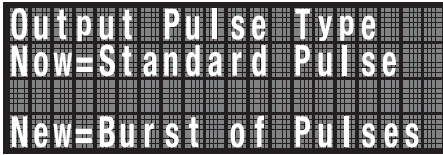

Output Pulse Type
Now=Standard Pulse
New=Burst of Pulses

Fig. 2.27

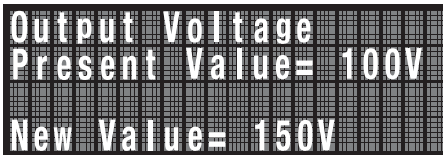

Output Voltage
Present Value= 100V
New Value= 150V

Fig. 2.28



Cycle Frequency
Present Value= 30Hz
New Value= 40Hz

Fig. 2.29

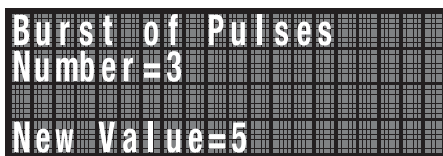

Burst of Pulses
Number=3
New Value=5

Fig. 2.30

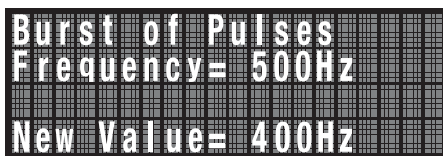

Burst of Pulses
Frequency= 500Hz
New Value= 400Hz

Fig. 2.31

If you select more burst pulses than possible at the selected cycle frequency (the low frequency), the LR-24 will automatically increase the burst frequency (the high frequency), to allow the selected number of pulses to be output. The LR-24 will not allow users to choose a burst frequency that is too low to produce the number of pulses that have been selected at the cycle frequency selected.

The following example demonstrates how to set up a Burst of Pulses:

1. Press the Pulse Type key on the front of the LR-24. Use the arrow keys to select Burst of Pulses for the new pulse type. The display will look like this:
2. Press the Enter key.
3. Press the Volts key and use the arrow keys to set the voltage to 150 volts, then press the Enter key.
4. Press the Freq.key and use the arrow keys to set the cycle frequency to 40 Hz, then press the Enter key.
5. Press the Duty Cycle key and use the arrow keys to set the number of pulses to 5, then press the Enter key.
6. Use the arrow keys to set the burst frequency to 400Hz, then press the Enter key.

DISPLAY PANEL MENU KEY

USER'S MANUAL

Display Panel Menu Key Descriptions (Cont.)

7. Use the arrow keys to set the duty cycle of the burst pulses to 25%, then press the Enter key.

```
Burst of Pulses
Duty Cycle= 50%
New Value= 25%
Width= 0.6mS
```

Fig. 2.32

8. You can now use the arrow keys to review the settings for the burst of pulses.

```
Output Waveform
Burst of 5 Pulses
(400Hz 25%) 40Hz
Volts= 150V
```

Fig. 2.33

Figure 2.34 shows the waveform that was set up in the preceding example. The lone pulse on the right side of the figure is the first pulse of the next group of 5 pulses. The height of each pulse is 150 volts. The groups of 5 pulses repeat at a 40Hz rate. Each one of the individual pulses is on for 25% of the time from the start of one pulse to the start of the next pulse in the group.

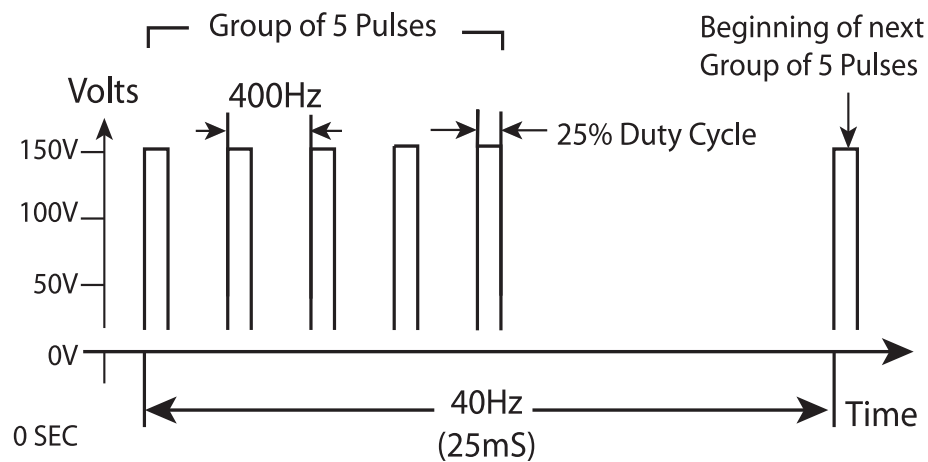

Fig. 2.34

Battery Compartment and Connections

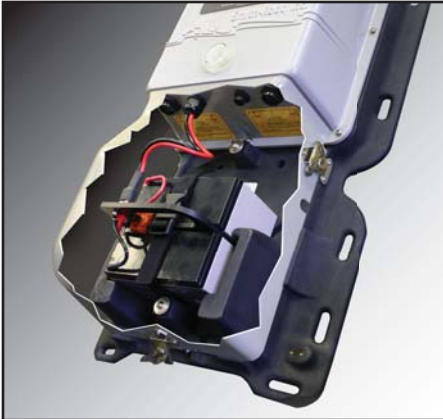

Fig. 3.1

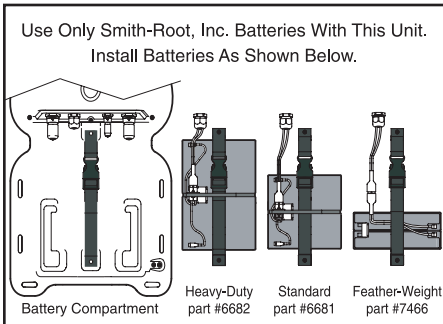

Fig. 3.2

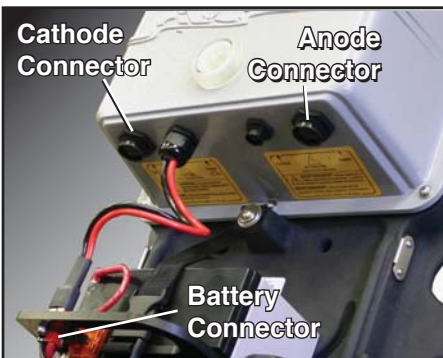

Fig. 3.3

Battery Compartment

Opening the battery compartment allows the user to install or change the battery, or connect the anode, cathode and control circuit connectors. Remove the battery compartment cover by flipping the handles on the 3 cam-lock latches out and turning them counter-clockwise. Make sure the latch on the bottom of the cover is free, then pull out on the 2 side latches and lift the battery compartment cover away from the LR-24.

When replacing the battery compartment cover adjust it so that it is on the inside of the molded guides of the pack frame. **The cover must be correctly placed before the LR-24 will operate.**

Close the cover latches.

Battery Connector

The battery connector, located inside the battery compartment, is a rectangular red and black plastic connector on the end of the input power cable. It mates with an identical connector on the LR-24 battery packs. This connector is color coded and polarized to prevent accidental reverse connections of the battery.

Anode and Cathode Connectors

The anode and cathode connectors are black plastic circular 2-pin connectors located on the bulkhead between the battery compartment and the electronics compartment. Access to these connectors is gained by removing the battery compartment cover. The connectors are identical and allow the use of a trailing cathode cable or a cathode pole for greater control over placement of the output electric field. Both pins in these connectors are live when the LR-24 is on. These connectors are polarized, 1/4 turn, locking connectors.

Control Connector

The control connector is a smaller 4-pin version of the anode and cathode connectors. It is also polarized and the smaller size prevents incorrect connections. The LR-24 utilizes a low voltage control circuit for added safety

SAFETY FEATURES

Emergency Shutdown Switch

The large red mushroom switch located on the top of the LR-24 is the Emergency Shutdown Switch, which is also the main on/off switch for the LR-24. To turn the power on the user must rotate the switch 90 degrees in the direction of the arrows (clockwise). Since the switch knob must be rotated, it helps to prevent accidentally powering up the LR-24. Pushing the red mushroom knob down until it latches will immediately turn the LR-24 off.



Fig. 4.1

Quick Release Pack Frame

The LR-24 has an integral quick release pack frame. Just press the latch tabs on the waist belt and shoulder straps and the entire LR-24 falls away.

CAUTION: Always unlatch the chest strap of the pack before entering or crossing water. If left latched this strap may prevent the user from quickly removing the LR-24 in the event of an emergency, such as falling into deep water.

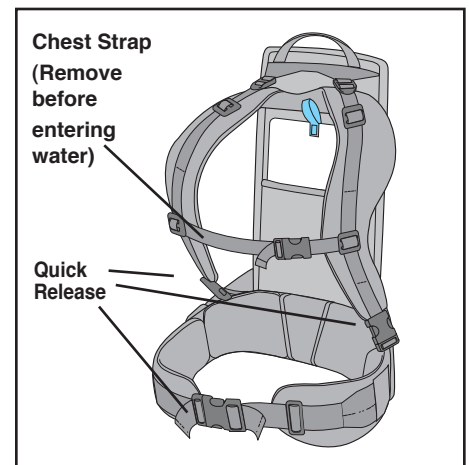

Fig. 4.2

Flashing Red Light

Bright long life LED lamps flash whenever the LR-24 is turned on and 30 volts or more is present between the anode and cathode.



Fig. 4.3

Safety Features Descriptions (cont.)

SAFETY DO'S AND DON'T'S

Do's:

1. Always be sure that all personnel are clear of the electrodes before turning on the power.
2. Know how to administer first aid treatment for electrical shock.
3. Wear flotation devices.
4. Have electrical circuits checked only by qualified technicians.
5. Disconnect the power supply when the electrofisher is not in use.

Don'ts:

1. Don't electrofish alone!
2. Don't continue to electrofish if the boots or gloves get wet inside.
3. Don't operate an electrofisher if have had any prior heart ailments.
4. Don't electrofish when are tired.

Audio Alarm

The audio output alarm indicates 4 different LR-24 operating conditions and is composed of two tone-emitting units; one high pitched and the other low pitched.

1. Presence of high voltage in the water

Whenever the anode and cathode are in the water and more than 30 volts is present, there will be an audible tone emitted by the alarm.

2. Average power output level

The Audio Alarms emit pulsed tones to indicate average power output level:

Average power output level	
Watts	Audio Tone in secs.
0 to 99.9	1 pulse per second
100 to 199.9	2 pulses per second
200 to 299.9	3 pulses per second
300 to 400	4 pulses per second

3. Power Limit mode: When the LR-24 output power reaches the user set power limit, the audio tone alternates between the high and low pitch at the rates specified above.

4. Dual Output mode: In this mode, the LR-24 can operate with a primary or secondary user-specified voltage/waveform combination. The selection between the two combinations is accomplished by rapidly double pressing the anode pole switch. The primary voltage/waveform is assigned to the high-pitched tone and the secondary voltage/waveform is assigned to the low-pitched tone.

Anode Switch

A magnetic reed switch is used for the anode pole switch. This switch has direct shutdown control of the high voltage output safety relay inside the LR-24. Releasing the flapper for the switch turns the switch off.

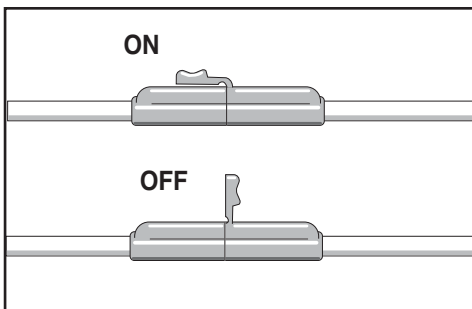

Fig. 5.1

Safety Features Descriptions (Cont.)

Tilt Switch

The tilt switch automatically turns off the output of the LR-24 if the LR-24 is tipped too far from vertical in any direction. The maximum forward tilt is 55 degrees from vertical. The maximum backward tilt is 35 degrees from vertical. The maximum side to side tilt is 45 degrees from vertical +/- 10 degrees.

If tilted beyond these limits, an error message is displayed. This condition is reset by moving to a more vertical position and releasing and pressing the anode pole switch.



Immersion Sensor

If the lower end of the LR-24 comes into contact with the water, the output is automatically shut off and an error message is displayed. This condition is reset by moving the LR-24 case out of contact with the water and then turning the power off and back on again. Note that if the battery compartment has filled with water, it must be drained before resetting the LR-24.



Anode Out of Water

This feature disables the output of the LR-24 and displays an error message whenever the anode pole switch is depressed and less than 30 milliamps, mA, of current is flowing between the anode and cathode. To restart the LR-24, place the electrode in the water and press the anode pole switch.

For working in very shallow water, this feature can be turned off using System Menu 5: Anode Out of Water Disable.

Note: This function is reactivated automatically when battery power is turned off and back on.



Fig. 5.3

Output Voltage Detector

This circuit senses voltage between the anode and cathode of the LR-24 and activates the audio alarm and a flashing red light if the LR-24 is turned on. Minimum detection voltage is 30 volts. This will occur whenever 30 volts is present in the water, regardless of whether the LR-24 is turned on or not.



Fig. 5.2

Electronic Circuit Breaker

The input of the LR-24 is protected by an electronic circuit breaker which shuts off all power to the LR-24 in the event of excessive battery drain. The breaker trips at an input current of 27 amps.



Fig. 5.4

Safety Features Descriptions (Cont.)

The LR-24 and Temperature

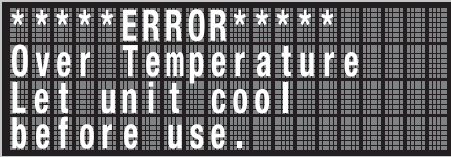

Fig. 5.5

If the LR-24 is working hard on hot days, it may overheat and shut down.

If the air temperature in the box reaches 160F or if the heat sink reaches 200F, an over-temperature error message will be displayed and the output will be disabled until the LR-24 cools down.

When using any of the pulsed outputs, the LR-24 can reduce the frequency of the output pulses automatically based on its internal temperature. This has the effect of reducing the power level of the LR-24 and therefore the heat being produced inside the system.

This can allow the LR-24 to continue to work instead of waiting for it to cool down again. This power reduction does not begin until the LR-24 is near the point of thermal overload, so under most conditions it does not affect the output at all. If unpulsed DC is being used the LR-24 can reduce the output voltage if it is near thermal overload. Again, this can allow the LR-24 to continue working instead of waiting for it to cool down. In both modes of operation as the LR-24 cools down, the output is increased back toward the original settings.

When enabled and the temperature of the LR-24 reaches the trip point, both of the audio alarms will begin to beep simultaneously and the **Thermal Limit** display will show the set frequency, or voltage, in the case of DC

Continued on next page...

Battery Compartment Interlock Switches

The cover of the battery compartment contains an interlock mechanism (A) that automatically turns off power to the LR-24 if the cover is opened. When replacing the battery compartment cover, adjust it so that it is on the inside of the molded guides (B) of the pack frame. **The cover must be correctly placed before the LR-24 will operate.**

RIGHT: Detail showing relative locations of Interlock Switch inside control box (not visible) and magnet inside of lid.

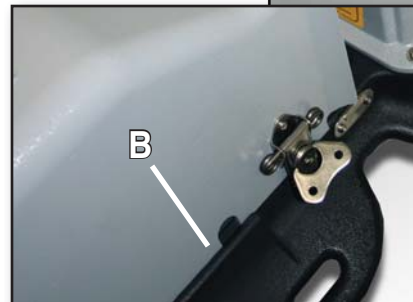
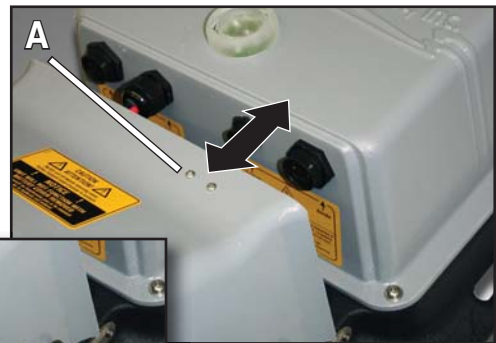

LEFT: Detail showing molded guides on pack frame. Lid must be aligned correctly and latched for unit to operate.

Fusible Links

The battery pack of the LR-24 incorporates a fusible link to protect the batteries from excessively high currents. In the event this fusible link blows out, it must be replaced with the same size and type as the original link in order to continue to provide protection for the battery pack and its wiring.

WARNING: Replacement of this link by anyone other than Smith-Root, Inc. will void the warranty of the entire electrofishing system.

Temperature Sensors

There are internal temperature sensors which can shut the LR-24 down if excessive temperatures are detected; If the LR-24 is shut down due to high temperature, an error message is displayed for as long as the temperature is above safe limits. After the LR-24 has cooled, the error message is cleared and full operation is automatically restored.

The Thermal Foldback Mode (System Menu 4) can help decrease the chance of shutdown due to excessive temperatures.

Safety Features Descriptions (Cont.)

Fault Conditions

Peak Current Overload

If the peak output current exceeds 40 amps, the output is disabled and an error message is displayed (See Fig. 5.6).

This is usually caused by a short circuit between the anode and cathode. The LR-24 can be reset by releasing the switch on the anode pole and pressing it again.



Fig. 5.6

Output IGBT Failure

If there is an Output Switch (IGBT) Failure, the LR-24's output is shut off and an error message is displayed (See Fig. 5.7).

The criteria for an Output Switch Fault is that output voltage has been detected when there should be none. For example, if the anode pole switch is not activated, there should be no output from the LR-24. If, however, output is detected, then an Output Switch Fault exists and the LR-24's output will be disabled. The LR-24 must then be sent back to Smith-Root for repair. Do not attempt to use the LR-24 if this message appears, as a safety hazard may exist and further use may cause more damage to the LR-24.



Fig. 5.7

Average Current Overload

The input and output currents of the LR-24 are constantly monitored while in use. If these currents become excessive, the LR-24 will shutdown it's output to prevent damage to it's circuits. Releasing the pole switch and selecting a lower output voltage or lower duty cycle waveform should clear this fault (See Fig. 5.8).



Fig. 5.8

Temperature continued

output and the reduced frequency or voltage based on the internal temperature of the LR-24. This display is shown as long as the pole switch is pressed. When the switch is released the standard status display is shown. This allows to see what the LR-24 is doing and what the internal temperatures are. It also allows users to continue to monitor the battery if desired. This option is explained in greater depth under System Menu 4.

Safety Features Descriptions (Cont.)

Fig. 5.9

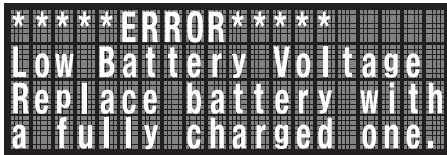

Fig. 5.10

Inverter Overload

If the Output Voltage is set too high for the water conductivity and the electrode spacing, the LR-24 will turn off its output and display an error message (see Fig. 5.9). The error message will suggest a more appropriate voltage for the present conditions. If this error is caused by a mistake, for example, temporarily having the Anode and Cathode too close together, acknowledge the error message by releasing the pole switch and pressing any key on the keypad.

If the error message shows up again in a short time, acknowledge the message and reduce settings to the suggested voltage before proceeding. This message occurs when the output voltage drops more than 30% below the voltage the user has set on the LR-24. This occurs when the water conductivity or electrode spacing (or both) are such that more power is being required from the LR-24 than it can supply. Note the average and peak power readings on the display. While the average power may be quite low, the peak power will be far above the 400 watts the LR-24 can supply on a continuous basis.

Low Battery Fault

When the battery is less than 20V, the LR-24 will shut down its output and display the Low Battery message (see Fig. 5.10).

Fig. 5.8

Turn off the power and replace the battery with one fully charged to clear this fault.

Battery Current Too Low

If the input current measuring circuit does not measure any current, this error message will appear and the power to the LR-24 will have to be turned off and back on to clear the message (see Fig. 5.11). This test is included to detect problems in the input current sensing circuit. If this error message appears again, the LR-24 will have to be sent to SRI for repairs.



Fig. 5.11

Set up and Operation

Make sure the Electrode ring is clean and shiny. A cloudy dull-gray Electrode ring will reduce catch per unit effort and will increase the fish injury rate. Initial set up of voltage, frequency, duty cycle and waveform should be done outside of the sample area to avoid influencing the statistics.

Basic Set up of the LR-24:

1. Make sure the power switch on the top of the LR-24 is in the OFF position (pressed DOWN).
2. Attach the anode and cathode to their output connectors. Attach the smaller connector on the anode cable to the control connector of the LR-24. Determine desired position of anode and cathode cables. They can be set up to exit the battery compartment either from the bottom or the sides. To run the cables out the bottom of the battery compartment, place the cables in the molded troughs, then install the battery and attach the power cord. Place the strain reliefs of the anode and cathode cables in the slots at the bottom of the pack frame, adjust the battery cover so that it is on the inside of the molded guides of the pack frame. The cover must be correctly placed before the LR-24 will operate (see **figures 6.1 and 6.2**). To run cables out the sides of the battery compartment, install the battery and attach the power cord of the LR-24 then route the cables thru the slots in the sides of the battery compartment cover. Adjust the battery cover so that it is on the inside of the molded guides of the pack frame. The cover must be correctly placed before the LR-24 will operate. Close the cover latches (see **figures 6.3 and 6.4**).
3. Put the LR-24 on. Be sure to know the location of the quick release buckles for the backpack and unlatch the chest strap before entering or crossing the water (refer to **Appendix E: Pack Adjustments** for further instructions).
4. Check with each crew member to be sure they know are ready to turn on the power.

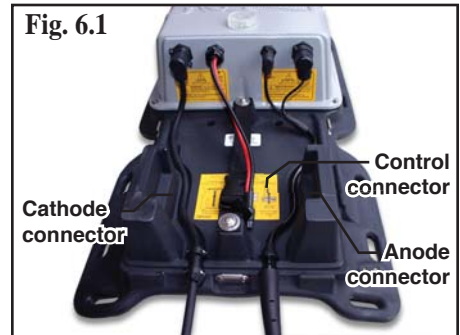

Set up and Operation (Cont.)



```
****ERROR****
Unit Tilted too far
Return to upright
position to clear.
```

Fig. 6.5

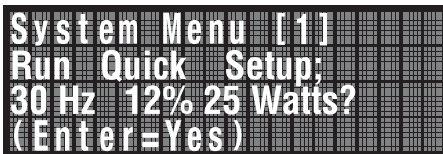

```
System Menu [1]
Run Quick Setup;
30 Hz 12% 25 Watts?
(Enter=Yes)
```

Fig. 6.6

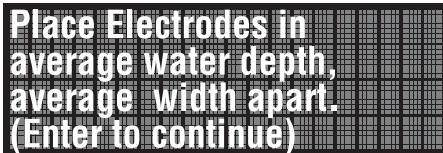

```
Place Electrodes in
average water depth,
average width apart.
(Enter to continue)
```

Fig. 6.7

Fig. 6.8

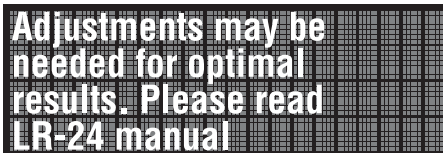

```
Adjustments may be
needed for optimal
results. Please read
LR-24 manual
```

Fig. 6.9

5. Turn on the power. *Do not press the anode switch.* Check the operation of the tilt switch by bending forward until the tilt switch activates, (about 55 degrees) and the tilt message appears on the display (see **Figure 6.5**). Straighten up and the status display should return. If the tilt message does not appear, do not use the LR-24; send it to Smith-Root for repair.
6. Place a dampened cloth on the immersion sensor contacts located on the lower right-hand corner of the LR-24, under the battery compartment. The display should show the immersion warning (see **Figure 6.5**). When the cloth is removed and the power is turned off and back on, the display should return to the status screen. If the immersion message does not appear, do not use the LR-24; send it to Smith-Root Inc. for repair.
7. Press the menu key.
8. Next, press the up arrow key until the Quick Set up option of the menu appears (see **Figure 6.6**).
9. Press Enter.
10. Make sure the cathode cable is behind and then place the anode ring in the water in front of (see **Figure 6.7**).
11. Press the switch on the anode pole and hold the flapper down until the audio tone stops (see **Figures 6.8 & 6.9**).

Quick Set up is now done.
12. The LR-24 is now set up and ready to begin electrofishing.

Set up and Operation (Cont.)

Quick Set up adjusts the LR-24 to produce 30 Hz, 12% duty cycle at 25 watts average output power. This is only a suggested starting point; and any or all of the output settings may be changed by the user at any time. Duty cycle and frequency can have a huge impact on taxis. Do not be timid about changing these settings. In general, lower frequencies are safer for larger fish than higher frequencies. If you are not getting any response from fish at all, change the LR-24 settings as follows:

- a. Increase the voltage 50 volts, press the Enter key and try again. Stop increasing voltage when begin getting a forced response (twitch), from the fish when pressing the anode pole switch.
- b. If fish are not showing taxis, increase the duty cycle by 10%, press the Enter key and try again. If necessary, repeat this step until you elicit taxis in the fish. If the duty cycle is increased to maximum and taxis is still not achieved, reduce the duty cycle back to 12% and go to the next step.
- c. Increase the frequency by 10 Hz, press the Enter key and try again. If necessary, go back to step "a" before increasing frequency again.

Observe the collected fish closely. In general, if it takes more than 5 seconds for a fish to recover it may have been shocked too much. If it takes more than 15 seconds for a fish to recover it was definitely shocked too much; reduce the frequency, duty cycle or output voltage of the LR-24.

Taxis and Tetany

There may be some confusion between taxis and tetany. Taxis is an induced swimming action. The nerves have time to repolarize and the muscles have time to relax between output pulses of the electrofisher. Tetany is locking up the muscles. The fish is stiff and there may be some slight quivering in the fins. While the fish may move toward the anode (positive electrode), this is not taxis. The output of the electrofisher should be reduced.

"Rolling fish over" should be avoided when electrofishing. With settings high enough to quickly knock fish out injury rate is higher than it should be. Ideally, fish will swim into the net while following the anode. Recovery time is zero, the fish is able to swim normally immediately upon being placed in the holding tank. It should not take more than 5 seconds for a fish to recover after being placed in the holding tank. If it takes 15 seconds or more for fish to recover after being placed in the tank, then reduce the output settings of the electrofisher.

Before Electrofishing:

The most experienced members of the electrofishing crew should be doing the netting. They know what to expect, what to look for and where to look. The next most experienced member should be running the LR-24, looking for likely habitat. The next most experienced member of the crew should be taking care of the recovery tank. The tank should be kept out of the sun, water temperature checked regularly and oxygen levels in the tank checked if the fish are held very long before being worked up and released.

Never electrofish with unauthorized people standing on the bank. Under certain conditions the field of the electrofisher can travel long distances. Things to look for include sheet piling, metal culverts, buried pipes, suction lines for irrigation, etc.

Set up and Operation (Cont.)

Recall Set up Key:

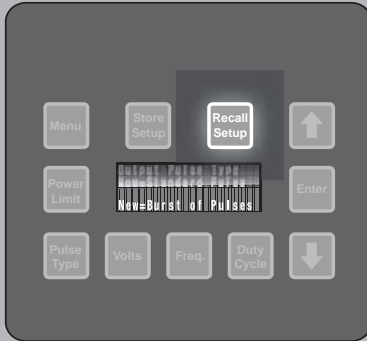

This key allows users to access the 10 factory default settings or settings that they have stored.

Since user-selected settings are stored in the same location as the factory default settings, the recall procedure is the same.

See also:

- Storing user-selected settings
- Recalling Factory-Default Settings
- Appendix D

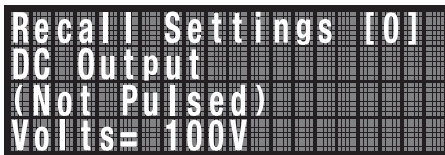

Fig. 6.10

Using Recalled Waveforms for Set up

Refer to the procedures (1-5) in the set up section.

1. Press the Recall key and use the up and down arrow keys to scroll forward or backward through the stored list of set ups. The display will show one set up at a time. When the end of the waveform list is reached, the LR-24 will wrap around to the beginning of the list.
2. When you find the desired waveform, press the Enter key. The factory default stored waveforms are listed below and in Appendix D.
3. You are ready to begin electrofishing.
4. Observe the reactions of the fish. It may be necessary to adjust the settings. Duty cycle and frequency can have a huge impact on taxis. In general, lower frequencies are safer for larger fish than higher frequencies. If you are not getting any response from the fish at all, change the LR-24 settings as follows:
 - a. Increase the voltage 50 volts, press the Enter key and try again. Stop increasing voltage when begin getting a forced response (twitch) from the fish when pressing the anode pole switch.
 - b. If fish are not showing taxis, increase the duty cycle by 10%, press the Enter key and try again. If necessary repeat this step until you elicit taxis in the fish. If the duty cycle is increased to maximum and taxis is still not achieved, reduce the duty cycle back to 12% and go to the next step.
 - c. Increase the frequency by 10 Hz, press the Enter key and try again. If necessary, go back to step “a” before increasing frequency again.
5. Observe the collected fish closely. In general, if it takes more than 5 seconds for a fish to recover, it may have been shocked too much. If it takes more than 15 seconds for a fish to recover it was definitely shocked too much; reduce the frequency, duty cycle, or output voltage of the LR-24.

Factory Default Stored Waveforms:

0. DC, 100 volts, 400 watt power limit.
1. Standard pulse 30 Hz, 25% duty cycle, 100 volts, 400 watt power limit.
2. Standard pulse 60 Hz, 25% duty cycle, 100 volts, 400 watt power limit.
3. Standard pulse 15 Hz, 25% duty cycle, 100 volts, 400 watt power limit.
4. Standard pulse 90 Hz, 25% duty cycle, 100 volts, 400 watt power limit.
5. Standard pulse 120 Hz, 25% duty cycle, 100 volts, 400 watt power limit.
6. Burst of three pulses, at 500Hz with 50% Duty cycle, 15Hz cycle frequency, 100 volts, 400 watt power limit.
7. Burst of three pulses at 500Hz with 50% Duty cycle, 30Hz cycle frequency, 100 volts, 400 watt power limit.
8. Dual output mode waveform.
Primary waveform - Burst of two pulses at 4Hz with 25% duty cycle, 1Hz cycle frequency, 100 volts, 400 watt power limit.
Secondary waveform - Standard Pulse 30 Hz, 25% duty cycle, 100 volts, 400 watt power limit.
9. Dual output mode waveform.
Primary waveform - Burst of three pulses at 4Hz with 25% duty cycle, 1Hz cycle frequency, 100 volts, 400 watt power limit.
Secondary waveform - Standard Pulse 30 Hz, 25% duty cycle, 100 volts, 400 watt power limit.

Set up and Operation (Cont.)

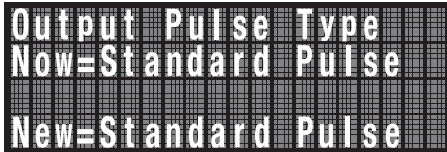

Output Pulse Type
Now=Standard Pulse
New=Standard Pulse

Fig. 6.11

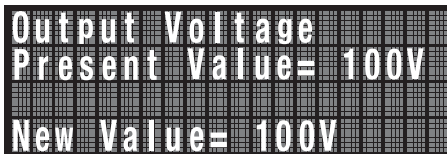

Output Voltage
Present Value= 100V
New Value= 100V

Fig. 6.12

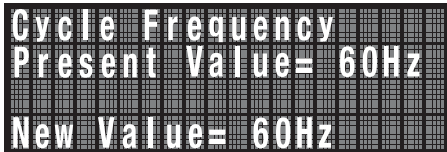

Cycle Frequency
Present Value= 60Hz
New Value= 60Hz

Fig. 6.13

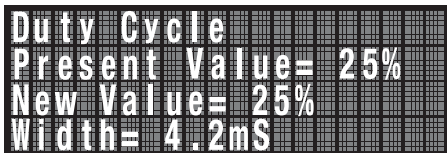

Duty Cycle
Present Value= 25%
New Value= 25%
Width= 4.2mS

Fig. 6.14

User-Selected Settings

This procedure allows operators to select settings to electrofish with. The proper procedure involves selecting the waveform or pulse type, voltage, frequency, duty cycle and power limit. See section on Burst of Pulses Waveforms, if this is to be the selected pulse type.

Refer to the procedures (1-5) in the set up section.

1. When turn on the LR-24, it recalls the waveform setting that was in use when the LR-24 was previously turned off. Check the waveform setting by pressing the up arrow until the waveform is displayed. If were previously using the LR-24 in Dual Output mode, the displayed waveform is the primary waveform. Pressing the up arrow again will cause the secondary waveform to be displayed. If Dual Output mode is not in use, then pressing the up arrow the second time will display the first status screen. If the displayed waveform is not the setting wish to use, continue with the next step; otherwise, begin electrofishing.
2. Press the pulse type key and then use the arrow keys to set the waveform you want to use. If unsure, set the pulse type to standard pulse. Press the Enter key.
3. Press the Volts key and use the arrow keys to set the voltage want to use. If you are unsure of what voltage to use, set the voltage to 100V.
4. Press the Enter key.
5. Press the Freq. key and use the arrow keys to set the frequency want to use. If you are unsure what frequency to use, set the frequency at 30Hz. Press the Enter key.
6. Press the Duty Cycle key and use the arrow keys to set the duty cycle percentage want to use. If you are unsure, set the duty cycle to 12%. Press the Enter key.
7. Press the Power Limit key and use the arrow keys to set the maximum average power want to put into the water. If you are unsure what value to use, set the power limit to 400 watts. Press the Enter key.

Set up and Operation (Cont.)

8. Place the anode ring and cathode cable approximately 12 inches (30 cm.) apart in ankle deep water.
9. Press the anode pole switch and listen to the audio alarm. If it is beeping on and off 1 time per second, release the anode pole switch and increase the output voltage 50 volts and press the Enter key. Press the anode pole switch again and listen to the tone. If the audio alarm is beeping on and off two or more times per second, release the anode pole switch and begin electrofishing. If not, repeat this step until the audio alarm begins beeping on and off faster than one time per second.
10. Begin electrofishing.

NOTE:

Duty cycle and frequency can have a huge impact on taxis. In general, lower frequencies are safer for larger fish than higher frequencies. If you are not getting any response at all from fish, change the LR-24 settings as follows:

- a. Increase the voltage 50 volts, press the Enter key and try again. Stop increasing voltage when begin getting a forced response, (twitch), from the fish when press the anode pole switch.
- b. If fish are not showing taxis then increase the duty cycle by 10%, press the Enter key and try again; if necessary repeat this step until elicit taxis in the fish. If increase the duty cycle to maximum and still are not getting taxis then reduce the duty cycle back to 12% and go to the next step.
- c. Increase the frequency by 10 Hz, press the Enter key and try again. Go back to step "a" before increasing frequency if necessary.

Observe the captured fish closely. In general, if it takes more than 5 seconds for a fish to recover, it may have been shocked too severely. If it takes more than 15 seconds for a fish to recover, it was definitely shocked too much; reduce the power limit, duty cycle, frequency, or output voltage of the LR-24.



Fig. 6.15

Set up and Operation (Cont.)

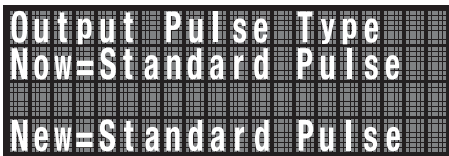

Fig. 6.16

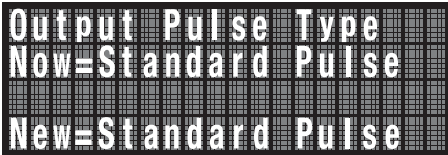

Fig. 6.17

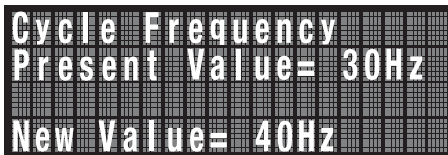

Fig. 6.18

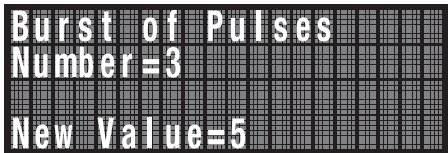

Fig. 6.19

Burst of Pulses Waveforms

The burst of pulses waveform is a composite of two waveforms. A lower frequency waveform (the cycle frequency), used to turn on and off a higher frequency waveform (the burst frequency). The following procedure will guide through setting up a gated burst waveform on the LR-24.

1. Press the Pulse Type key.
2. Press the down arrow key until Burst of Pulses appears on the display. Then press the Enter key.
3. Press the Freq. key and use the arrow keys to set the desired cycle frequency. Then press the Enter key.
4. Press the Duty Cycle key and use the arrow keys to set the desired number of pulses in the burst. Press the Enter key (see **Figure 6.19**). Use the arrow keys to set the pulse frequency. Press the Enter key (see **Figure 6.20**). Use the arrow keys to set the duty cycle of the pulse waveform, then press the Enter key (see **Figure 6.21**). Press the Volts key and use the arrow keys to set the output voltage, then press the Enter key. All three steps must be completed for any changes to be effected.
5. Press the Power Limit key and use the arrow keys to set the power limit. Then press the Enter key.
6. Begin electrofishing.

Set up and Operation (Cont.)

NOTE:

Duty cycle and frequency can have a huge impact on taxis. In general, lower frequencies are safer for larger fish than higher frequencies. If you are not getting any response from fish at all, change the LR-24 settings as follows:

- a. Increase the voltage 50 volts, press the Enter key and try again. Stop increasing the voltage when begin getting a forced response (twitch), from the fish when press the anode pole switch.
- b. If fish are not showing taxis, increase the duty cycle by 10%. Press the Enter key and try again. If necessary, repeat this step until you elicit taxis in the fish. If you increase the duty cycle to maximum and still are not getting taxis, reduce the duty cycle back to 12% and go to the next step.
- c. Increase the frequency by 10 Hz press the Enter key and try again. If necessary, go back to step “a” before increasing frequency again.

With the LR-24 set as above, begin electrofishing. Closely observe the captured fish. In general, if it takes more than 5 seconds for a fish to recover it may have been shocked too severely. If it takes more than 15 seconds for a fish to recover it was definitely shocked too much; reduce the power limit, duty cycle, frequency, or output voltage of the LR-24.

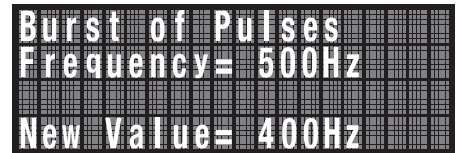

Fig. 6.20

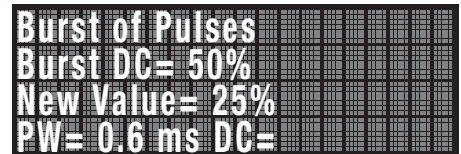

Fig. 6.21

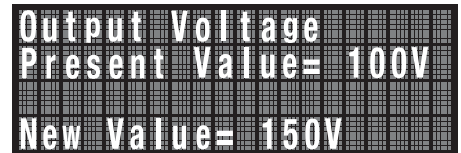

Fig. 6.22



Fig. 6.23

Set up and Operation (Cont.)

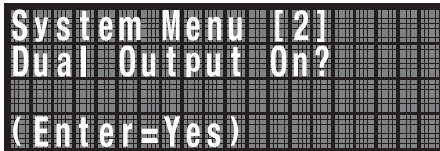

Fig. 6.24

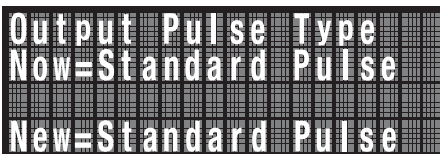

Fig. 6.25

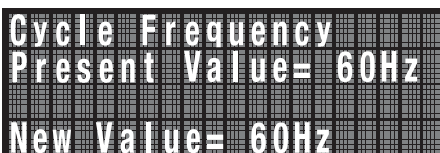

Fig. 6.26



Fig. 6.27

Dual Output Mode

In this mode of operation, the user sets up two waveforms and two output voltages. The first waveform entered is called the primary waveform and is the one activated when the user first presses the anode pole switch. The secondary waveform is the second one entered and is activated from the primary waveform by releasing and then pressing the anode pole switch again in less than one second (double clicking). The pulse type, output voltage, frequency and duty cycle for both the primary and secondary waveforms are set in a straightforward manner using the front panel keys. This feature quickly allows the user to change the output of the LR-24. Users may wish to do this if, for example, they are working with juveniles and suddenly come across an adult. The primary waveform is indicated by a higher tone than the secondary waveform, so it is always easy to tell which waveform the LR-24 is producing. The primary waveform is indicated by a high-pitched (2.9KHz) tone. The LR-24 indicates when the user changes to the secondary waveform by changing to a lower-pitched (1.9KHz) tone. Releasing the anode pole switch for more than 1 second and then pressing it again will cause the LR-24 to toggle back to the primary waveform.

The following procedure will guide through setting up Dual Power Mode:

1. Press the Menu key and use the arrow keys to scroll to the Dual Power Mode (On/Off) option. Press the Enter key (see **Figure 6.24**).
2. Press the Pulse Type key and use the arrow keys to scroll to the waveform type want to use for the primary waveform, then press the Enter key. The available waveform types of the LR-24 are: DC (non-pulsed), Standard pulse and Burst of pulses (see **Figure 6.25**).
3. Press the Freq.key and use the arrow keys to scroll to the desired waveform frequency and then press the Enter key (see **Figure 6.26**).
4. Press the Duty Cycle key and use the arrow keys to scroll to the desired duty cycle and then press the Enter key. Note that if DC was selected as the pulse type, neither frequency nor duty cycle can be selected for that waveform as these have no meaning for DC. If burst of pulses was selected, two frequencies and two duty cycles must be set (see **Figure 6.27**).

Set up and Operation (Cont.)

5. Press the Volts key and use the arrow keys to scroll to the desired voltage and then press the Enter key (see **Figure 6.28**).
6. Press the Power Limit key and use the arrow keys to scroll to the desired power limit and then press Enter (see **Figure 6.29**).
7. Repeatedly press the up arrow key until the Secondary Waveform parameters are displayed. Repeat steps 2 through 6 for the Secondary Waveform.
8. Begin electrofishing.
9. Duty cycle and frequency can have a huge impact on taxis. In general, lower frequencies are safer for larger fish than higher frequencies. If you are not getting any response from fish at all, change the LR-24 settings as follows:
 - a. Increase the voltage 50 volts press the Enter key and try again. Stop increasing voltage when you begin getting a forced response (twitch), from the fish when pressing the anode pole switch.
 - b. If fish are not showing taxis then increase the duty cycle by 10% press the Enter key and try again. If necessary, repeat this step until you elicit taxis in the fish. If increasing the duty cycle to maximum still does not achieve taxis, reduce the duty cycle back to 12% and go to the next step.
 - c. Increase the frequency by 10 Hz, press the Enter key and try again. If necessary, go back to step “a” before increasing frequency again.
10. Observe the caught fish closely. In general if it takes more than 5 seconds for a fish to recover, it may have been shocked too severely. If it takes more than 15 seconds for a fish to recover, it was definitely shocked too much. Reduce the power limit, duty cycle, frequency, or output voltage of the LR-24.

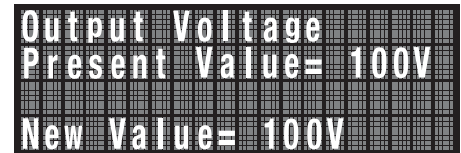

```
Output Voltage
Present Value= 100V
New Value= 100V
```

Fig. 6.28



```
Power Limit Setup
Present Value=400W
New Value=400W
```

Fig. 6.29

Set up and Operation (Cont.)

Storing User-Selected Settings

The LR-24 can store 10 different waveform settings. This gives the user the capability of saving different settings that might work particularly well at different sampling sites. This can simplify setting up the LR-24 when return to that site later to sample again. This reduces variability caused by slightly different set ups used by different crews. The LR-24 always starts up with the same settings as it had when it was last turned off. The factory default waveforms can be restored to the storage locations by selecting the Restore Factory Defaults option under the menu key. When a set up is stored in a storage location, the set up that was there previously is overwritten and lost. To save a set up, follow the procedure below:

1. Press the store key.
2. Use the arrow keys to scroll to a storage location want to overwrite.
3. Press the Enter key. The pulse type, frequency, duty cycle, voltage and power limit are all stored for instant recall and later use.

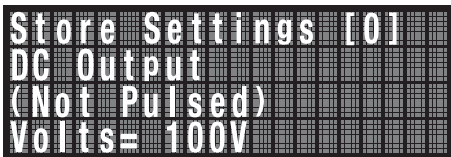

Fig. 6.30

LR-24 Specifications*

Conductivity Range	10-1500 microsiemens/cm ³
Input Voltage	24 VDC Nominal
Input Current	20 Amps Max.
Input Monitoring	Battery voltage and current plus easy to read fuel gauge type display for battery voltage
Output Voltage	50 to 990 Volts in 5 volt steps
Output Current	4 Amps continuous at 100 Volts, 40 Amps peak max.
Output Waveforms	Smooth DC, Pulsed DC, Burst of Pulses DC
Output Frequency	1 Hz to 120 Hz in 1 Hz steps (Burst of Pulses frequencies up to 1000Hz)
Output Waveform Duty Cycle	1% to 99% in 1% steps
Waveform Storage	Save up to 10 different waveforms for quick easy recall of voltage, frequency, duty cycle and pulse type
Output Power	400 watts maximum continuous; 39,600 watts peak
Operational Duty Cycle	40% Max. (192 seconds on 288 seconds off) at 40 C ambient 400VA output
Operational Altitude	0 to 3000 meters
Overload Protection	Excessive peak current, average current, or over-temperature will shutdown the electrofisher before damage can occur. Resets automatically when condition is corrected
Output Indicator	Audio tone for 30 VDC and greater with increasing pulse rate for output power, Flashing red light, Status display for output voltage both average and peak, output current both average and peak and output power, both average and peak
Output On Timer	0-999,999 seconds, resettable via menu
Operating Temperature Range	0 C to 40 C.
Storage Temperature Range	-15 C to 50 C.
Humidity Range Operating or Nonoperating	10% to 90% noncondensing
Construction	Sealed molded polyethylene and ABS case NEMA 4, IP 65
Safety Devices	Tilt switch: Forward 50 degrees, backward 40 degrees, sideways 45 degrees all +/- 10 degrees, Immersion sensor, Anode out of water sensor, Anode pole switch, Emergency stop switch, Battery compartment interlock, Battery fusible link, Quick release pack
Battery	24 V, 7Ah, sealed, deep discharge with 40 A fusible link, 12 lb 5.45 kg
Battery Life	40 minutes continuous at 100 watts
Weight	33 lbs 17.0kg with battery
Dimensions	27.5H x 14.5W x 14.5D including suspension
*Specifications subject to change without notice.	

Custom Stored Waveforms

My Custom Stored Waveforms

Please use this page to record any custom waveform set ups. For DC there are no entries in the Frequency or Duty Cycle columns. For standard waveforms there is one entry in each column. For burst waveforms there are two entries in the Frequency and Duty Cycle columns. For dual waveforms record two entries in the same storage location, one for the Primary waveform and one for the Secondary waveform. If it becomes necessary to send the Electrofisher in for repair, these settings may be lost and would need to be re-entered in the system.

Storage Location	Voltage	Frequency (Burst/Cycle)	Duty Cycle (Burst/No. Pulses)	Pulse Type (DC, Standard, Burst)
0				
1				
2				
3				
4				
5				
6				
7				
8				
9				

Battery Care and Maintenance

Battery Charger

The Smith-Root **BC-24PS** is a revolutionary concept in battery charger design. This high technology, compact device offers a number of benefits not found in conventional chargers. The BC-24PS is a truly automatic charger tailored for maintenance-free batteries as well as other types of lead acid batteries.

The BC-24PS has a fully automatic, four stage charge sequence with an electronically timed routine and a desulfation mode.

Stage 1 Desulfation: encourages the breakdown of larger sulfate crystals which form during prolonged periods of deep discharge.

Stage 2 Constant current: applied to achieve the fastest possible return of energy to the battery.

Stage 3 Constant voltage: temperature compensated with adaptive timing to insure maximum charge for each battery, this stage provides the final 20% of the total charge.

Stage 4 Standby float-charge: this stage will replace standing losses and keep the battery in a full charged state. Batteries may be left in this state indefinitely provided that they are in a well vented area and the AC input is not subject to frequent or periodic power outages (switched outlet or bad power).

Damage to or failure of the battery may cause the charger to stay in high-rate mode with subsequent battery venting. In these situations consider using a MC-24 charger (not subject to these limitations) for long term battery storage.

Time to recharge will vary depending on state of charge, condition of battery and battery size. The rule of thumb is 2 to 3 hours for lightweight, 2.5 to 4 hours for standard weight and 3 to 6 hours for heavy weight batteries.

These charge times are for a battery recently discharged to the low battery cutout on an electrofisher.

A fully charged battery placed on a BC-24PS charger may not indicate that it is fully charged for as long as 1 1/2 hours due to the timed charger feature.

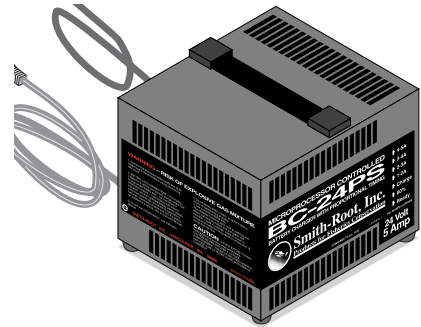

Specifications

Input 120 Volts AC 60Hz, 200 VA
Output 5 Amps DC 24 Volts
Dimensions 6.5"W x 5.25"H x 6.0"D
Weight 9.5 lbs.

BC-24PS Batt. Charger.....04954

Battery Care and Maintenance (cont.)

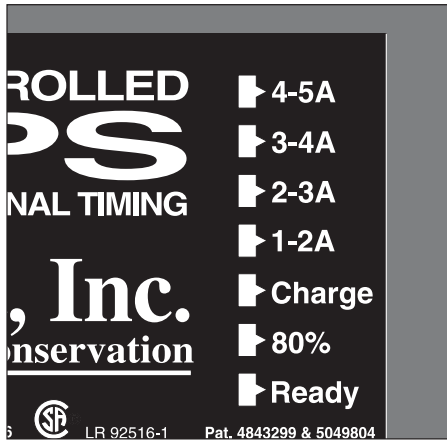

Fig. 7.1

Battery Charger: Connectors and Indicators

Input power cord: The input power plug is a standard 120VAC three-pin with ground.

Output cord and connector: The connector on the end of the cord is wired to plug directly into the quick-disconnect connector on the battery pack.

Front panel indicators: The seven front panel indicator lamps are labeled to indicate the battery's state of charge. (see fig. 7.1)

Charger Operating Instructions

This charger is suitable for use with all types of lead acid batteries, including the new types of maintenance free and gelled electrolyte batteries.

1. Connect charger to battery.
2. Connect the charger to the AC power. The state of charge is shown by the LED indicators on the battery charger as follows. The red "Charge" LED will light to indicate that the battery is correctly connected and is charging. During charging, the current flowing into the battery is indicated by the LED Amp Meter. This is the vertical group of four red LEDs located directly above the "Charging" LED. At the start of charge, if the battery is in normal condition, all four red LEDs will be on and will gradually go out in sequence as the charge current drops and the battery approaches full charge. When the battery reaches an 80% level of recharge, the red "Charge" LED will go off and the yellow "80%" LED below it will come on. After a further time interval, the "80%" LED will go off and the green "Ready" LED will come on. The time interval for this final 20% of charge is automatically adjusted by the charger in proportion to the time taken to reach the 80% level.
3. The length of time needed for recharging will depend on the size and depth of discharge of the battery. A minimum of one hour is needed and full charging of a large battery may take up to 12 hours.
4. **IMPORTANT SAFETY NOTE:** When disconnecting the battery from the charger, switch off or unplug the AC supply to the charger first. This precaution will eliminate any risk of gas explosion due to arcing.

Battery Care and Maintenance (cont.)

Batteries

The electrofisher uses a 24 volt sealed deep cycle battery. Understanding the proper care of this battery will reduce problems in the field.

Batteries should never be allowed to remain in a discharged state and should be recharged as soon as possible after use. Batteries should be charged until the green lamp on the charger comes on.

Charging Problems: Some older batteries may not charge within 24 hours. If a battery has been left in a discharged condition for a while, it may not take a charge. If suspect that the battery has been left discharged, charge it for 48 hours and then discharge it with the electrofisher. If the battery is not taking a charge, it will not operate the electrofisher for very long. Sometimes by cycling the battery a few times it will start taking a charge again.

Note that all batteries should be charged after each use even if the battery was only slightly discharged (these batteries do not have a memory). Total number of charge/discharge cycles possible varies inversely with depth of discharge on each cycle. Over-discharging or completely discharging the battery will greatly reduce the cycles possible and a battery left in a discharged condition may be ruined. For this reason, batteries should never be allowed to remain in a discharged state. Recharge as soon as possible after each use.

Service Life: Batteries which have been properly maintained should last 3 to 5 years depending on ambient temperature, depth of discharge (D.O.D.) and number of cycles (for Smith-Root batteries to maintain at least 80% of original capacity, they are rated 230 cycles for 100% D.O.D., 470 cycles for 50% D.O.D. or 1100 cycles for 30% D.O.D.). Batteries which have reached this end of life condition may still be useful where shorter operating times are appropriate.

Shipping: These batteries conform to the UN2800 classification as "Batteries, wet, non-spillable, electric storage". They conform to the International Air Transport Association (I.A.T.A.) Special Provision A67, classifying them as non-dangerous goods and are therefore exempt from the subject regulations for dangerous goods and are acceptable for transport on both cargo and passenger aircraft.

Reference: I.A.T.A. Dangerous Goods Regulations, 35th Edition, Jan 1, 1994 Section 4.4, Special Provisions:



Fig. 7.2 24 V 12 AH



Fig. 7.3 24 V 7 AH

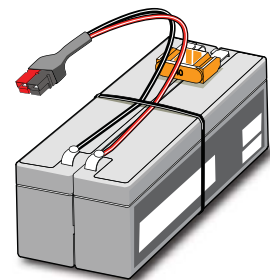

Fig. 7.4 24 V 2.2 AH

24 V 12 AH Battery.....	06682
24 V 7 AH Battery.....	06681
24 V 2.2 AH Battery.....	07466

Battery Care and Maintenance (cont.)

Battery Storage Instructions

Fully charge batteries before placing in storage. As these batteries will self discharge, we recommend that they be recharged after 3 or 4 months of storage at 20 degrees centigrade. More frequent charging is required at higher storage temperatures and less at lower temperatures (9 months at 0 degrees). Batteries removed from storage should be recharged for a least 48 hours prior to placing back in service. If batteries are stored on a maintenance charger (MC-24), they are always ready for use.

When not in use, store the charger indoors in a cool dry place, preferably with it's original packing and carton.

Maintenance And Cleaning

Very little maintenance is required other than protecting the charger from damage and weather.

1. Coil cord when not in use.
2. Clean case and cords with a slightly damp cloth.
3. Examine cords for damage periodically and replace if necessary with manufacturer approved parts.

Battery Tips & Precautions

1. Keep the battery charged! The most frequent cause of battery failure is not recharging after each use.
2. Heat kills batteries. Avoid storage in exceedingly warm areas. Recommended operating temperatures are between 5 and 35 degrees C (maximum - 15 to 50 degrees C). The energy available on a given discharge cycle decreases at low temperatures and increases at higher than normal temperatures. Increased temperatures increase the gradual processes of very slow corrosion which normally occur in all lead acid batteries.
3. Avoid heavy vibrations or shocks, which may cause internal damage. Foam packing is cheap insurance.
4. Avoid contact with oils or solvents which may attack the battery case (ABS plastic resin). Clean with soap and water only.
5. Do not crush, incinerate or dismantle the battery. The electrolyte contains sulfuric acid which can cause serious damage to eyes and skin. Dispose of old batteries at a battery recycler.

Battery Care and Maintenance (cont.)

BATTERY SPECIFICATIONS

Rating: Batteries are rated at the current which will reduce the voltage per cell to 1.67 volts in 20 hours. The heavyweight battery has a 12 amp hour rating. However its life at 100 watt continuous would be only 120 minutes. As the discharge current is increased, the efficiency and relative capacity decrease.

Battery Life: Each time cycle a battery it loses some of its ability to take a charge. Deep cycle batteries are capable of being charged and discharged from 100 up to 1,000 times, depending on the depth of the discharge and the type of charger used. Service life and shelf life are both adversely affected by warmer temperatures.

Battery Storage: Batteries stored at room temperature will self-discharge at 3% to 6% per month. Storage temperature above 20°(68°F) should be avoided. Shelf life can be increased by storing at lower temperatures, but store at above -30°C to prevent freezing. Batteries should be fully charged before storing and should be recharged every four months.

Effects of Temperature: The temperature at which a battery is used also affects the relative capacity of the battery. Figures 7 and 8 show that in cold weather the shocking time will be less and the battery will have less capacity.

Life	Load	Capacity
20 hr	0.60A	12.0Ah
10 hr	1.05A	10.5Ah
5 hr	1.95A	9.7Ah
1 hr	7.20A	7.2Ah
30 min	12.00A	6.0Ah
15 min	20.00A	5.0Ah

Fig. 7.5 Relative capacity of 12Ah deep cycle battery.

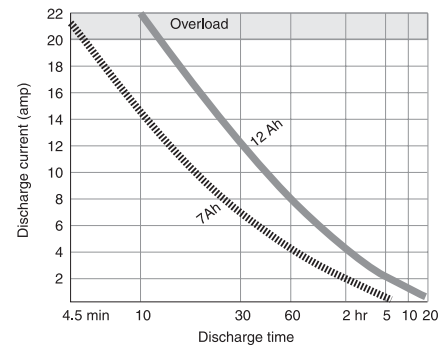

Fig. 7.6 Discharge curves for 12Ah and 7Ah batteries.

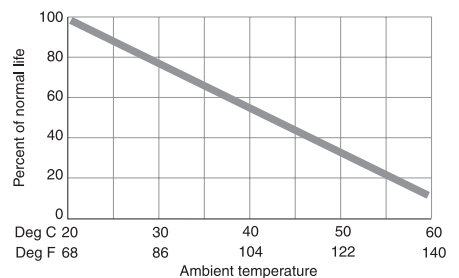

Fig. 7.7 Effect of temperature on battery life.

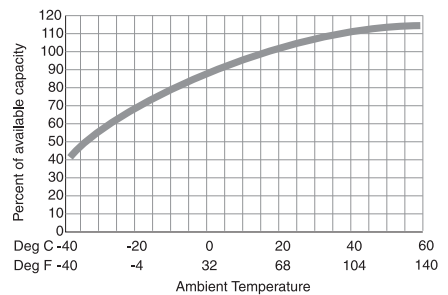

Fig. 7.8 Effect of temperature on capacity.

Battery Maintenance & Diagnostic Equipment

MC-24 MAINTENANCE CHARGER

The Smith-Root MC-24 Maintenance Charger (sold separately) is specifically designed for proper battery maintenance and storage.

Trickle charging optimizes battery shelf life by reducing cell deterioration. Keeping batteries fully charged can greatly increase battery life. The MC-24 eliminates the hassle of shuffling batteries from shelf to charger and keeps batteries properly charged and ready for service. With the built-in battery evaluation load test function and maximum charge indicators, can see the state of charge and condition of each battery and identify low charged and worn-out batteries. Charging batteries using the MC-24 takes between two and four days. It is also an excellent cost effective alternative to purchasing multiple battery chargers, because it can recharge four batteries at once.

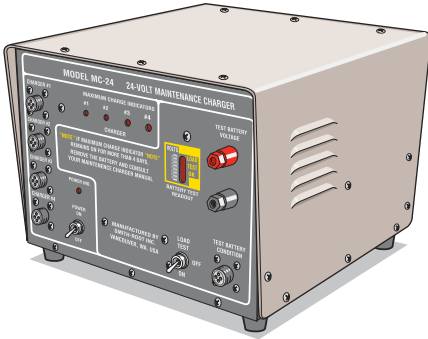

Fig. 8.1 MC-24 Maintenance Charger

BAT-01 BATTERY ANALYSIS TOOL

The Battery Analysis Tool (sold separately) operates in conjunction with the BC-24PS Battery Charger. It tests all models of 24 V backpack batteries (adaptors included) and in a clear and concise manner gives the usable battery life remaining.

This tool is not to be used during each charge / discharge cycle, but rather is intended to be used a few times a year, just prior to actually using the batteries. It may also be used to accurately test any Smith-Root 24 Volt battery where the battery condition is either unknown or is questionable.

In practice, The Battery Analysis Tool is plugged into a standard Smith-Root BC-24PS and also the battery under test. The battery will begin to charge as soon as the charger is plugged in (Do not use an MC-24 Maintenance Charger for this test).



Fig. 8.2 BAT-01 Battery Analysis Tool

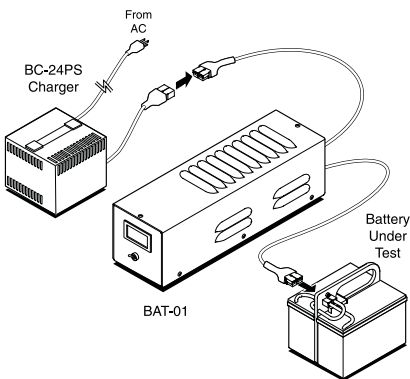

Fig. 8.3 BAT-01 Battery Analysis Tool

MC-24 Maintenance Charger	06811
BAT 01 Battery Analysis Tool	08041

Electrofishing Safety



Electrofishing equipment uses voltages and currents that can be lethal to humans. The operators must always keep in mind that the chance of receiving an electrical shock is multiplied in or near water. Using an electrofisher is like using a firearm: if used properly and with good judgment it is perfectly safe; lose respect for it and you can lose your life!

Electrical equipment used in a moist field environment is always subject to deterioration that could lead to dangerous electrical shock. Field equipment is also subjected to vibration and impact during transporting and while in operation. Often equipment shared by different crews does not receive proper maintenance or a complete checkout.

Follow the safety guidelines and use good common sense to handle unforeseen circumstances.

PROPER EQUIPMENT

To prevent electrical shock, all electrical equipment should be carefully inspected before each field operation. With all electrical equipment in good operating condition and all insulation junction boxes, bonding and connections intact, there is much less danger of receiving an electrical shock.

Make sure that:

- Electrofisher gives audible sound when voltage is present at anode.
- Quick release system is functioning properly.
- Tilt switch is functioning properly (turns power off).
- use dipnets with non conductive handles.
- Electrodes are free from corrosion (clean if necessary), Anode does not have netting jury-rigged to ring (a common, ill-advised modification), Cathode is free of wear and burrs and its cable insulation is undamaged.
- Poles are free of cracks in fiberglass handle.
- Power Supply- check all batteries for damage / leakage. (disconnect power supply before transporting and when not in use.)
- Always purchase electrofishing equipment from an authorized dealer.

Electrofishing Safety (Cont.)

WHAT IS ELECTRICAL SHOCK?

It is the current that passes through the human body that does the damage. The voltage is relevant, because it is the force that “pushes” the current through the body. Experiments show that 20 to 500 Hz AC current is more dangerous than DC, or higher frequencies of AC.

The voltages used by electrofishing gear can cause death by one of three means:

Ventricular Fibrillation

Ventricular fibrillation is uncoordinated contraction of the muscles of the heart. The heart quivers rather than beats. Electrical current through the chest can cause this condition. Once a person goes into ventricular fibrillation, the only way to stop the quivering is to use a defibrillator that applies a pulse shock to the chest to restore heart rhythm. Cardiopulmonary resuscitation may help to keep a victim alive until he can be defibrillated.

Respiratory Arrest

The respiratory center is at the base of the skull. Thus, shocks to the head can cause the breathing to stop. Artificial respiration by the mouth-to-mouth method should be used in this case.

Asphyxia

Asphyxia is caused by contraction of the chest muscles.

When a current is above a certain level, a person cannot let go of an electrically hot wire. Currents above this level may not cause ventricular fibrillation, but may be enough to cause contraction of the chest muscles. If the current is not stopped, or the victim is not removed from the point of electrical contact, asphyxia will result. Artificial respiration or cardiopulmonary resuscitation may be necessary.

Personal protective equipment

- First aid kit.
- Non-breathable chest waders or non-breathable hip boots with non slip soles.
- Lineman electrical gloves rated and tested at a minimum of 1,000 volts.
- Check personal protective equipment for leaks and holes.

Optional:

- Brimmed hat
- Polarized sunglasses
- Life jacket and or wading belt
- Raincoat

Crew Preparation:

Designate a crew leader.

For safety reasons, there should be a minimum of two person crews. Never electrofish alone.

Crew leader responsibilities:

Designate 1 person to order power of the electrofisher to be turned on.

Clarify with the entire crew nearest hospital and evacuation route in case of an accident.

Make it clear that any member of the crew can order power off.

Crew responsibilities:

All crew members should be trained in fundamentals of electricity and safety.

As electrofishing is inherently dangerous, all crew should be alert and attentive; take breaks as necessary.

Emergency Planning

In case of an accident:

Turn off power to the electrofisher.

Evaluate situation and take appropriate action.

Electrofishing Safety (Cont.)

PREVENTING ELECTRICAL SHOCK

Electricity needs to have a complete electrical circuit in order for current to flow. The only way that can get shocked is if become the electrical conductor to complete the circuit. The current flows from the cathode to the anode through the water. The water is the electrical conductor. If someone touched both the anode and the cathode, they would become an electrical conductor and complete the circuit path and get a severe electrical shock. If someone were to touch only one of the electrodes, they would not complete the electrical circuit and not get shocked.

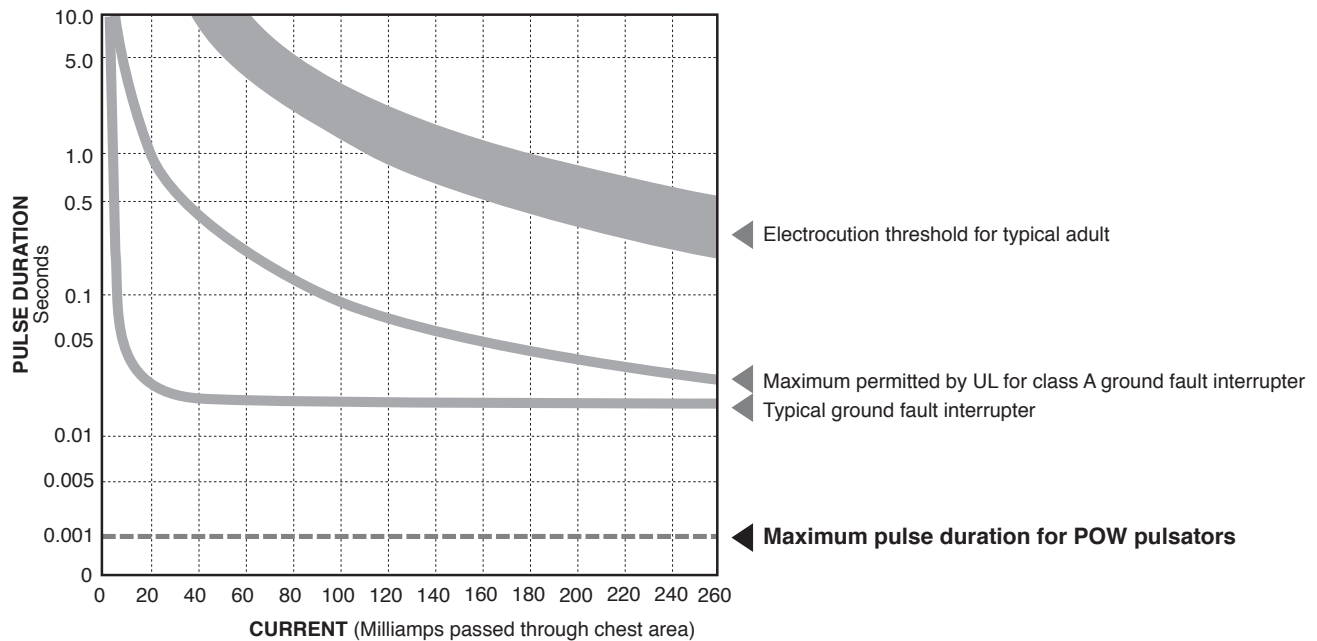

Effects on humans of an electrical pulse passed through the chest area

WARNING: *Touching any electrode is not recommended. Unless all conductive objects come into contact with are connected to the same electrode, will be shocked to find a current path that is not obvious, e.g., the water, or the boat.*

Preventing electrical shock means preventing electrical current from entering and flowing through parts of the body. The skin is a partial but variable barrier, because it offers resistance to the passage of electrical current. Tough skin has more resistance than tender skin and dry skin more than wet skin. But tough, dry skin alone does not offer enough protection for electrofishing. Rubber lineman’s gloves rated 1,000V minimum should always be worn. Even while wearing rubber gloves and waders, never touch an electrode while the circuit is energized. Do not work on the electrical system while the generator is running. Do not enter the water while the current is on during boom shocking operations.

A severe electrical shock from electrofishing gear may result in the need for artificial respiration; therefore, it is imperative that no one ever works alone.

To prevent electrical shock all electrical equipment should be carefully inspected before each field operation. With all electrical equipment in good operating condition and all insulation, junction boxes, bonding and connections intact, there is much less danger of receiving an electrical shock.

Electrofishing Safety (Cont.)

Electrofisher Operation



1. Electrofish only as far as you can safely wade. Some areas are unreachable with a backpack electrofisher.
2. Touching an electrode is not recommended, even while wearing Lineman's gloves and waders.
3. Never electrofish with spectators on shore. Electric fields can travel large distances through buried pipes, metal culverts and metal sheet piling.
4. If spectators show up during electrofishing, stop the operation and go to explain to them what you are doing. Explain the risks to them being there and ask them to please leave for their own safety. If they refuse to leave, stop electrofishing, load the equipment and leave the area.

WARNING: Operating this equipment in a manner not specified in this manual, making modifications, or using accessories not approved by Smith-Root, Inc. may impair the protection offered by the equipment.



- Have electrical circuits checked only by qualified technicians.
- Turn off the electrofisher before Making any connections or part replacements.
- Release chest strap before entering the water.
- Shut off power before entering or leaving the water.
- Stop work immediately if get water in hip boots, waders, or gloves.
- Operate slowly and carefully to prevent slips and falls.
- Always be sure that all crew members are clear of electrodes before turning power on and before energizing electrodes.
- Don't operate an electrofisher if have any prior heart ailments, wear a pacemaker or are pregnant.

Electrofishing Safety (Cont.)

Quick release system

It may be necessary in some circumstances to remove the electrofisher backpack quickly.

The LR-24 has an integral quick release pack frame. Just press the latch tabs on the waist belt and shoulder straps and the entire LR-24 falls away.

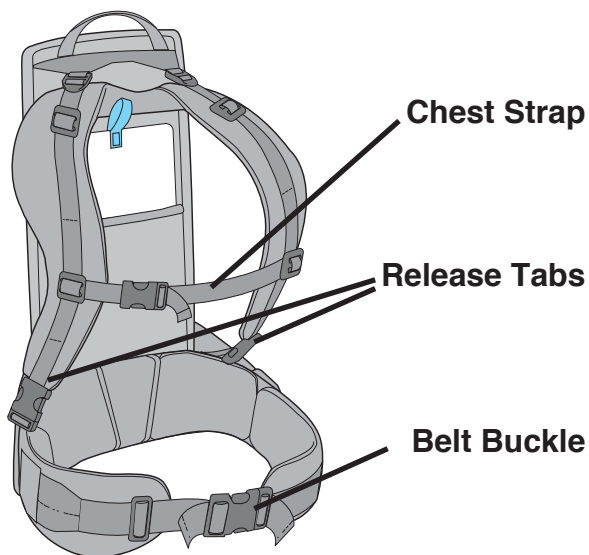

CAUTION: Always unlatch the chest strap of the pack before entering or crossing water. If left latched this strap may prevent the user from quickly removing the LR-24 in the event of an emergency, such as falling into deep water.

This should only be done in an emergency situation! The backpack may be damaged from contact with the ground and/or water when using the quick release system.

The following procedure illustrates how the quick release system is designed to work.

1. Squeeze the release tabs on hip belt buckle to remove hip belt.
2. Squeeze the release tabs on either shoulder strap.
3. With strap detached, shrug off opposite strap. This will allow the pack to fall away from you very quickly!
4. Move away from pack as it falls.



Appendix A: Glossary of Terms

- Amp:** The unit of measure expressing the quantity of electricity flowing in a circuit. Analogous to water quantity flowing in a pipe. Amp is an abbreviation for Ampere.
- Anode:** The positive terminal on a battery or electrode on an LR-24.
- Cathode:** The negative terminal on a battery or electrode on an LR-24.
- Conductivity:** A measure of the ease with which electricity can flow through a substance. In electrofishing, the substance of interest is water. Conductivity is measured in mS (micro-Siemens, or millionths of a Siemen). Distilled water has a conductivity of 0 mS, while brackish water has a conductivity of 10,000mS or more.
- Current:** Generic term that refers to the flow of electricity in a circuit. Unit of measure is the Amp.
- Duty Cycle:** Expresses the ratio, in %, of on time to off time for an electrical signal such as an LR-24 output. For example, if an LR-24 output is ON for .25 seconds and OFF for 1 second the duty cycle is $.25/1 * 100 = 25\%$.
- Electrofisher:** An apparatus that applies electricity to a body of water for the purpose of stunning fish.
- Frequency:** The rate at which an electrical signal changes over time. The unit of measure is the Hertz. One Hertz is equal to one change (cycle) per second and is abbreviated Hz. For example, if an LR-24 is producing 60 pulses per second, the frequency would be 60 Hz.
- Hertz:** The unit of measure for frequency. See Frequency.
- IP:** Acronym for Ingress Protection. Various IP standards exist that specify the ability of an enclosure to keep out contaminants such as dust and water. IP65 applies to the LR-24 enclosure and signifies that it is dust-proof and will protect from a water-jet spray in all directions, but is not suitable for immersion.
- mA:** Milliamp. One thousandth of an Amp; see AMP.
- mSec:** Millisecond. One thousandth of a second.
- NEMA:** Acronym for National Electrical Manufacturers Association. NEMA sets contamination protection standards that apply to the LR-24 enclosure.
- Operational Duty Cycle:** Expresses the ratio in percentage of shocking time to battery power on time.
- Volt:** The unit of measure expressing the 'pressure' behind an electrical current. Analogous to water pressure pushing water through a pipe.
- Volt-Amp:** Unit of measure of electrical power equivalent to the Watt. Abbreviated VA.
- Watt:** Unit of measure of electrical power. 1 Watt = 1Amp * 1Volt. Abbreviated W.

Appendix B: LR-24 Event Codes

The following are the event codes that the LR-24 logs in its internal event history. Each entry contains a code followed by the hardware time when the event happened. This time represents total shocking time since the LR-24 was built.

Code	Display Message	Description	Cleared By
U01	LR-24 Tilted Too Far	LR-24 has been tilted from vertical beyond safe limits.	Pole Sw.
U02	Immersion Detected	LR-24 has been immersed in water.	Power
U03	Low Output Current	Electrodes may be out of the water.	Pole Sw.
U04	Pole Switch on at Power-up.	Pole switch engaged when power was turned on.	Pole Sw.
U05	Voltage detected on output	A voltage above 30V is seen on the electrodes when the output is turned off, likely due to other LR-24s.	Automatic
P01	Peak Amps Overload	Electrodes likely have been shorted.	Pole Sw.
P02	Low Battery Voltage	Battery Has been drained, needs recharging.	Power
P03	Over Temperature	LR-24 has gotten too hot, let cool.	Pole Sw.
P04	High Battery Current	Too much power from battery, reduce output voltage or duty cycle.	Pole Sw.
P05	High Output Current	Average output current above 4 Amps, reduce output voltage or duty cycle.	Pole Sw.
P06	Inverter Overload	LR-24 unable to maintain requested output voltage into the current load. A lower output voltage will be suggested to help prevent failure. May require several attempts to find a voltage that will work.	Press Enter Key on Keypad.
S01	Low Battery Current	Measurement system failure, send in for repair.	Power
S02	50V Out Of Range	Voltage regulator failure, send in for repair.	Power
S03	150V Out Of Range	Voltage regulator failure, send in for repair.	Power
S04	300V Out Of Range	Voltage regulator failure, send in for repair.	Power
S05	500V Out Of Range	Voltage regulator failure, send in for repair.	Power
S06	800V Out Of Range	Voltage regulator failure, send in for repair.	Power
S07	Safety Relay Failure	The output safety relay is open, send in for repair.	Power
S08	No IGBT Output	The output switch is open, send in for repair.	Power
S09	IGBT HV Breakdown	The output switch fails at high voltage, send in for repair.	Power
S10	Output IGBT Failure	The output switch has shorted, send in for repair.	Power
S11	Memory Test Failure	The microprocessor has detected a failure and may not be reliable. Send in for repair.	Power
---	No Error	Place holder in history, not an error.	N/A

Appendix C: LR-24 Operation Hints



An Anode Ring with pronounced oxide coating.

Make sure the Anode ring is kept clean. Anode rings are made from aluminum and will eventually develop an oxide coating that will give the ring a dull appearance. This coating impairs the transfer of electricity from the electrode to the water and can be removed with fine steel wool.

To maximize battery life, always connect batteries to their charger as soon as possible after use.

Resist the temptation to put a net on Anode rings. Nets have the following very undesirable characteristics:



An Anode Ring with netting attached - never a good idea.

1. Nets present a safety hazard since it can place the operator's hands unnecessarily close to the electrode when removing fish.
2. The intensity of the electric field increases as the fish to electrode distance decreases. Therefore, the risk of injury to the fish is greatly increased with the use of an Anode-ring net.
3. Nets make the Anode ring more difficult to clean.

If maximizing the electrofishing time obtained on a set of batteries is of primary concern, then consider setting the power limit down to the lowest practical level. For instance, if good results are obtained at, say, 100W, then set the power limit to 100W. This will prevent unnecessary battery drain and reduce fish injury if the electrodes are brought close together.

Appendix D: Factory Default Stored Waveforms

0. DC, 100 volts, 400 watt power limit.
1. Standard pulse 30 Hz, 25% duty cycle, 100 volts, 400 watt power limit.
2. Standard pulse 60 Hz, 25% duty cycle, 100 volts, 400 watt power limit.
3. Standard pulse 15 Hz, 25% duty cycle, 100 volts, 400 watt power limit.
4. Standard pulse 90 Hz, 25% duty cycle, 100 volts, 400 watt power limit.
5. Standard pulse 120 Hz, 25% duty cycle, 100 volts, 400 watt power limit.
6. Burst of three pulses, at 500Hz with 50% Duty cycle, 15Hz cycle frequency, 100 volts, 400 watt power limit.
7. Burst of three pulses at 500Hz with 50% Duty cycle, 30Hz cycle frequency, 100 volts, 400 watt power limit.
8. Dual output mode waveform.
Primary waveform - Burst of two pulses at 4Hz with 25% duty cycle, 1Hz cycle frequency, 100 volts 400 watt power limit.
Secondary waveform - Standard Pulse 30 Hz, 25% duty cycle, 100 volts, 400 watt power limit.
9. Dual output mode waveform.
Primary waveform - Burst of three pulses at 4Hz with 25% duty cycle, 1Hz cycle frequency, 100 volts, 400 watt power limit.
Secondary waveform - Standard Pulse 30 Hz, 25% duty cycle, 100 volts, 400 watt power limit.

Appendix E: Adjusting the LR-24 Suspension System

Suspension System

The LR-24 suspension system has a wide range of adjustment to fit most people comfortably. The suspension system can be adjusted for body length by sliding sliptool or similar item down between the Shoulder Yoke and the mainframe in order to disengage the hook-and-loop fasteners and then adjust the suspension system to length.

Correct Fit



The standard suspension will fit 32" to 40" waists. Shoulder yokes with both larger and smaller shoulder straps are also available and can quickly and easily be changed using the same technique outline above.

Adjusting the LR-24 Suspension System (Cont.)

Making Suspension System Adjustments

The suspension system can be adjusted by sliding sliptool down between the Shoulder Yoke and the mainframe in order to disengage the hook-and-loop fasteners.

1. Pull the sliptool out of carrier pocket in front of shoulder yoke. This is the shipping position. Do not attempt to use the sliptool with a loaded packframe.
2. Push the sliptool between the shoulder yoke and the main frame. Push down to separate the hook and loop fasteners. The tool should go all the way to the bottom of the harness.
3. Move the shoulder yoke up and down to the correct torso length. Put LR-24 on, fasten hip belt to a comfortable position and have a partner adjust the shoulder yoke height.
4. Once have adjusted the shoulder yoke to the right torso length, have the partner remove the sliptool and place it back into its carrier pocket.

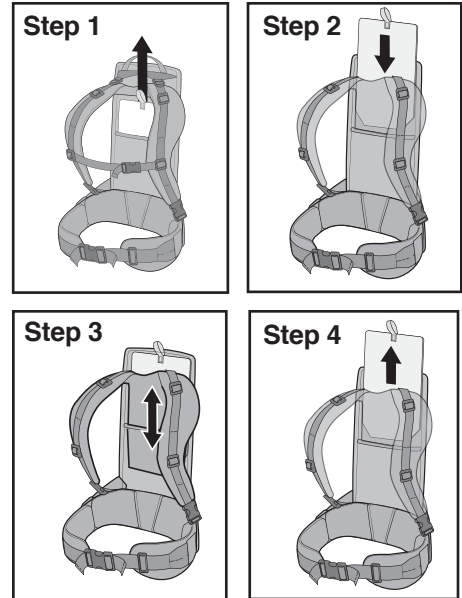

Adjustment Steps:

- With all straps loosened, begin fitting by securing the waist-belt snugly, so that approximately 75% of the weight rests comfortably on the hips.
- Next, tighten the lower shoulder yoke straps to distribute the remaining weight comfortably on the shoulders.
- Finally, tighten the upper shoulder yoke straps to draw the mainframe towards the shoulder blades.

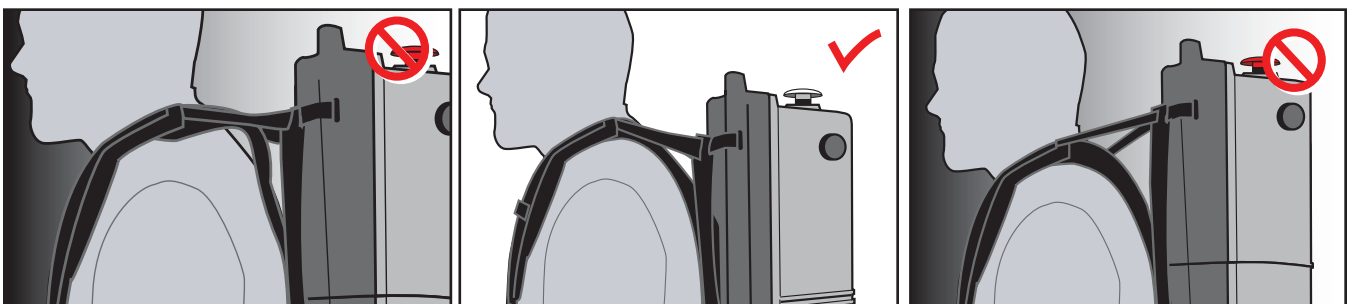

INCORRECT

Shoulder yoke is level with or above top of shoulders. Note slack in strap behind shoulders. Frame should be shortened.

CORRECT

Corner of shoulder yoke is level with top of shoulder blade. This is the most comfortable and stable way to wear unit.

INCORRECT

Shoulder yoke is lower than the top of shoulders. The unit is unstable and uncomfortable. Frame should be lengthened.

Appendix F: Cleaning and Maintenance

The LR-24 enclosure and suspension system may be both cleaned with warm water and a mild soap solution. Spray the solution on the area to be cleaned and then wipe with a soft cloth. Rinse grit from the touch panel with a stream of water before wiping with a cloth to avoid scratching the display window.

CAUTION: Do not use solvents on the case of the LR-24 as they may cause permanent damage to the LR-24.

Extended Maintenance Program

The extended maintenance program is a service contract offered to customers who have purchased SRI electrofishing equipment directly from our factory. It can be purchased for equipment that is past its standard one-year warranty. Older equipment is subject to eligibility parameters such as hours/years in service. Our Smith-Root factory technicians will perform cleaning of internal component parts, electronic repairs and calibration once (1) per year. During this maintenance period, upgrades to current specifications will be performed to factory standards. The unit will be recertified and issued a SRI certification label.

All labor and materials will be included in the yearly inspection.

Contact Smith-Root, Inc. for additional information.

Appendix G: Model 12-B/15-D Setting Chart

Use this chart to convert settings used with the 12-B or 15-D to settings on the LR-24.

Example: If F4 were used with the model 12-B, the corresponding settings for the LR-24 would be 30Hz at 12% Duty cycle. Note that as set the duty cycle the LR-24 display shows the pulse width (4ms in this case).

Standard Pulses							
	1	2	3	4	5	6	
A	1Hz	2ms	3ms	4ms	6ms	7ms	8ms
B	5Hz	1ms	2ms	3ms	4ms	6ms	8ms
C	10Hz	500µs	1ms	2ms	4ms	6ms	8ms
D	15Hz	500µs	1ms	2ms	4ms	6ms	8ms
E	20Hz	500µs	1ms	2ms	4ms	6ms	8ms
F	30Hz	500µs	1ms	2ms	4ms	6ms	8ms
G	40Hz	500µs	1ms	2ms	4ms	6ms	8ms
H	50Hz	500µs	1ms	2ms	4ms	6ms	8ms
I	60Hz	500µs	1ms	2ms	4ms	6ms	8ms
J	70Hz	500µs	1ms	2ms	4ms	6ms	8ms
K	80Hz	500µs	1ms	2ms	4ms	6ms	8ms
L	90Hz	500µs	1ms	2ms	4ms	6ms	8ms
M	100Hz	100µs	500µs	1ms	2ms	4ms	6ms
N	110Hz	100µs	500µs	1ms	2ms	4ms	6ms
O	120Hz	100µs	500µs	1ms	2ms	3ms	4ms

Wide to Narrow Varying Width					
Begin/End Values	7	8	9	10	11
	2sec	4sec	6sec	8sec	10sec
A	8-0.4ms	15Hz	15Hz	15Hz	15Hz
B	6-0.3ms	15Hz	15Hz	15Hz	15Hz
C	4-0.2ms	15Hz	15Hz	15Hz	15Hz
D	8-0.4ms	30Hz	30Hz	30Hz	30Hz
E	6-0.3ms	30Hz	30Hz	30Hz	30Hz
F	4-0.2ms	30Hz	30Hz	30Hz	30Hz
G	8-0.4ms	45Hz	45Hz	45Hz	45Hz
H	6-0.3ms	45Hz	45Hz	45Hz	45Hz
I	4-0.2ms	45Hz	45Hz	45Hz	45Hz
J	8-0.4ms	60Hz	60Hz	60Hz	60Hz
K	6-0.3ms	60Hz	60Hz	60Hz	60Hz
L	4-0.2ms	60Hz	60Hz	60Hz	60Hz
M	8-0.4ms	80Hz	80Hz	80Hz	80Hz
N	6-0.3ms	80Hz	80Hz	80Hz	80Hz
O	4-0.2ms	80Hz	80Hz	80Hz	80Hz

High to Low Varying Frequency					
Begin/End Values	12	13	14	15	16
	2sec	4sec	6sec	8sec	10sec
A	80-8 Hz	1ms	1ms	1ms	1ms
B	60-6 Hz	1ms	1ms	1ms	1ms
C	40-4 Hz	1ms	1ms	1ms	1ms
D	80-8 Hz	2ms	2ms	2ms	2ms
E	60-6 Hz	2ms	2ms	2ms	2ms
F	40-4 Hz	2ms	2ms	2ms	2ms
G	80-8 Hz	4ms	4ms	4ms	4ms
H	60-6 Hz	4ms	4ms	4ms	4ms
I	40-4 Hz	4ms	4ms	4ms	4ms
J	80-8 Hz	6ms	6ms	6ms	6ms
K	60-6 Hz	6ms	6ms	6ms	6ms
L	40-4 Hz	6ms	6ms	6ms	6ms
M	80-8 Hz	8ms	8ms	8ms	8ms
N	60-6 Hz	8ms	8ms	8ms	8ms
O	40-4 Hz	8ms	8ms	8ms	8ms

Appendix H: LR-24 Electrode/Cathode Testing

LR-24 Electrode Pole Testing

1. Connect an ohmmeter to the pins in the larger connector.
The meter should read 0 ohms.
2. Leave one lead of the ohmmeter connected to one of the pins in the large connector and connect the other lead of the meter to the metal socket in the bottom end of the pole.
The meter should read 0 ohms.
3. Refer to figure 1 below. Connect one lead of the ohmmeter to pin 1 of the small connector. Connect the other lead of the meter to pin 2 of the small connector. The meter should read infinite ohms.
4. Press the operator switch down against the rubber handle of the pole. The meter should read 0 ohms.

If the pole fails any of the tests above, the pole needs to be replaced. If the pole passes all of the tests above, then the problem is in the LR-24 and it should be returned to the factory for repair.

LR-24 Cathode Testing

1. Set the multi-meter to measure resistance and connect leads to the left and right pins of the connector on the end of the cathode cable. The meter should display close to 0 ohms between the 2 pins.
2. Move one of the leads to the bare metal cable. Again the meter should display close to 0 ohms between the pin in the connector and the bare cable. Flex the cable along its insulated length and watch the meter reading as do. Be careful to keep the ohmmeter securely connected while flexing the cable. If the meter reading changes significantly or jumps, the cable should be replaced.

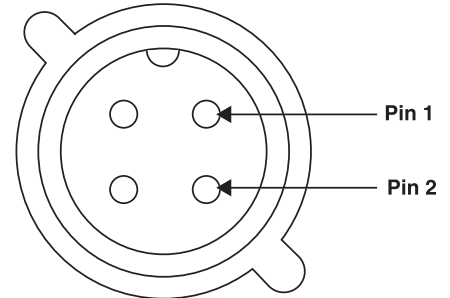

Fig. 9.1 Front view of Control Connector on end of Y-cord.

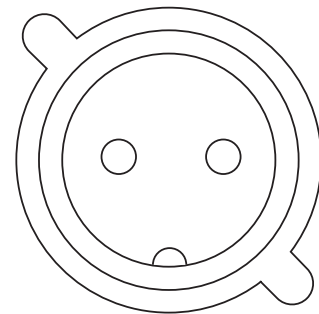
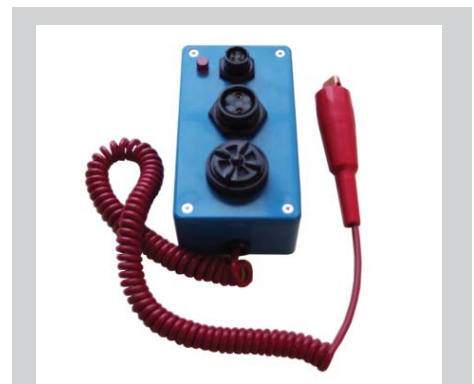

Fig. 9.2 Front view of Cathode Connector on end of Y-cord.



An easy to use plug-in tester is available from Smith-Root. It allows one person to perform easily the above tests, with an audible alarm and fault indicator light.

Electrode/Cathode Pole Tester.....08115

WARRANTY

Smith-Root, Inc. original products have a One Year Limited Warranty.

Smith-Root, Inc. warrants that its Products are free from defects in material and workmanship that result in Product failure during normal usage, according to the following terms and conditions:

1. The limited warranty for the Product extends for the length of ownership beginning on the date of the purchase of the Product by the original purchaser ("Consumer") of the Product and is not assignable or transferable to any subsequent purchaser or user.
2. The limited warranty extends only to Consumers who purchase the Product from Smith-Root, Inc. or an authorized distributor.
3. During the 1-year limited warranty period, Smith-Root, Inc. will repair, or replace, at Smith-Root, Inc.'s sole option, any defective parts, or any parts that will not properly operate for their intended use with new or refurbished replacement items if such repair or replacement is needed because of product malfunction or failure during normal usage. No charge will be made to the Consumer for any such parts. Smith-Root, Inc. will also pay for the labor charges incurred by Smith-Root, Inc. in repairing or replacing the defective parts. The limited warranty does not cover defects in appearance, cosmetic, labels or structural items, including framing and any non-operative parts. Smith-Root, Inc.'s limit of liability under the limited warranty shall be the actual cash value of the Product at the time the Consumer returns the Product for repair, determined by the price paid by the Consumer for the Product less a reasonable amount for usage. Smith-Root, Inc. shall not be liable for any other losses or damages. These remedies are the Consumer's exclusive remedies for breach of warranty.
4. Upon request from Smith-Root, Inc., the Consumer must prove the date of the original purchase of the Product by a dated bill of sale or dated itemized receipt.
5. The Consumer shall bear the cost of shipping the Product to Smith-Root, Inc. Smith-Root, Inc. shall bear the cost of shipping the Product back to the Consumer after the completion of service under this limited warranty.
6. The Consumer shall have no coverage or benefits under this limited warranty if any of the following conditions are applicable:
 - a) The Product has been subjected to abnormal use, abnormal conditions, improper storage, exposure to moisture or dampness, unauthorized modifications, unauthorized connections, unauthorized repair, misuse, neglect, abuse, accident, alteration, improper installation, or other acts which are not the fault of Smith-Root, Inc., including damage caused by shipping.
 - b) The product has been damaged from external causes such as collision with an object, or from fire, flooding, sand, dirt, windstorm, lightning, earthquake or damage from exposure to weather conditions, an Act of God, or battery leakage, theft, blown fuse, or improper use of any electrical source, or damage caused by the connection to other products not recommended for interconnection by Smith-Root, Inc.
 - c) Smith-Root, Inc. was not advised in writing by the Consumer of the alleged defect or malfunction of the Product within fifteen (15) days after the expiration of the applicable limited warranty period.
 - d) The Product serial number plate or the accessory data code has been removed, defaced or altered.
7. If a problem develops during the limited warranty period, the Consumer shall take the following step-by-step procedure:
 - a) The Consumer shall return the Product to Smith-Root, Inc. for repair or replacement processing.
 - b) The Consumer contacts the Customer Service Department at Smith-Root, Inc., at the number listed on the bottom of this page, for repair or replacement processing.
 - c) The Consumer shall ship the Product prepaid and insured. Expenses related to removing the Product from an installation are not covered under this limited warranty.
 - d) The Consumer will be billed for any parts or labor charges not covered by this limited warranty. The Consumer will be responsible for any expenses related to reinstallation of the Product.
 - e) Smith-Root, Inc. will repair the Product under the limited warranty within 30 days after receipt of the Product. If Smith-Root, Inc. cannot perform repairs covered under this limited warranty within 30 days, or after a reasonable number of attempts to repair the same defect, Smith-Root, Inc. at its sole option, will provide a replacement Product or refund the purchase price of the Product less a reasonable amount for usage.
 - f) If the Product is returned during the limited warranty period, but the problem with the Product is not covered under the terms and conditions of this limited warranty, the Consumer will be notified and given an estimate of the charges the Consumer must pay to have the Product repaired, with all shipping charges billed to the Consumer. If the estimate is refused, the Product will be returned freight collect. If the Product is returned after the expiration of the limited warranty period, Smith-Root, Inc.'s normal service policies shall apply and the Consumer will be responsible for all shipping charges.
8. The Product consists of newly assembled equipment that may contain used components that have been reprocessed to allow machine compliance with Product performance and reliability specifications.
9. ANY IMPLIED WARRANTY OF MERCHANTABILITY, OR FITNESS FOR A PARTICULAR PURPOSE OR USE, SHALL BE LIMITED TO THE DURATION OF THE FOREGOING LIMITED WRITTEN WARRANTY. OTHERWISE, THE FOREGOING LIMITED WARRANTY IS THE CONSUMER'S SOLE AND EXCLUSIVE REMEDY AND IS IN LIEU OF ALL OTHER WARRANTIES, EXPRESS OR IMPLIED. SMITH-ROOT, INC. SHALL NOT BE LIABLE FOR SPECIAL, INCIDENTAL OR CONSEQUENTIAL DAMAGES, INCLUDING BUT NOT LIMITED TO LOSS OF ANTICIPATED BENEFITS OR PROFITS, LOSS OF SAVINGS OR REVENUE, PUNITIVE DAMAGES, LOSS OF USE OF THE PRODUCT OR ANY ASSOCIATED EQUIPMENT, COST OF CAPITAL, COST OF ANY SUBSTITUTE EQUIPMENT OR FACILITIES, DOWNTIME, THE CLAIMS OF ANY THIRD PARTIES, INCLUDING CUSTOMERS and INJURY TO PROPERTY, RESULTING FROM THE PURCHASE OR USE OF THE PRODUCT OR ARISING FROM BREACH OF THE WARRANTY, BREACH OF CONTRACT, NEGLIGENCE, STRICT TORT, OR ANY OTHER LEGAL OR EQUITABLE THEORY, EVEN IF SMITH-ROOT, INC. KNEW OF THE LIKELIHOOD OF SUCH DAMAGES. SMITH-ROOT, INC. SHALL NOT BE LIABLE FOR DELAY IN RENDERING SERVICE UNDER THE LIMITED WARRANTY, OR LOSS OF USE DURING THE PERIOD THAT THE PRODUCT IS BEING REPAIRED.
10. Some states do not allow limitation of how long an implied warranty lasts, so the above warranty limitation may not apply to (the Consumer). Some states do not allow the exclusion or limitation of incidental and consequential damages, so certain of the above limitations or exclusions may not apply to (the Consumer). This limited warranty gives the Consumer specific legal rights and the Consumer may also have other rights which vary from state to state.
11. Smith-Root, Inc. neither assumes nor authorizes any authorized service center or any other person or entity to assume for it any other obligation or liability beyond that which is expressly provided for in this limited warranty including the provider or seller of any extended warranty or service agreement.
12. This is the entire warranty between the Smith-Root, Inc. and the Consumer and supersedes all prior and contemporaneous agreements or understandings, oral or written, relating to the Product and no representation, promise or condition not contained herein shall modify these terms.
13. This limited warranty allocates the risk of failure of the Product between the Consumer and Smith-Root, Inc. The allocation is recognized by the Consumer and is reflected in the purchase price.
14. Questions concerning this limited warranty may be directed to:

Smith-Root, Inc.
14014 NE Salmon Creek Ave.
Vancouver, WA 98686
(360) 573-0202

CORPORATE HEADQUARTERS:

SMITH-ROOT, INC.
14014 NE Salmon Creek Ave.
Vancouver, WA 98686 USA
360.573.0202 Voice
360.573.2064 FAX
info@smith-root.com

